

CE EMC Test Report

Report No.: CE170627D07

Test Model: FE-1071

Received Date: Jun. 28, 2017

Test Date: Jun. 29 ~ Jul. 10, 2017

Issued Date: Jul. 12, 2017

Applicant: Vecow Co., Ltd.

Address: 12F., No. 111, Zhongcheng Rd., Tucheng Dist., New Taipei City 23674
Taiwan (R.O.C.)

Issued By: Bureau Veritas Consumer Products Services (H.K.) Ltd., Taoyuan Branch

Lab Address: No. 47-2, 14th Ling, Chia Pau Vil., Lin Kou Dist., New Taipei City, Taiwan
(R.O.C.)



This report is for your exclusive use. Any copying or replication of this report to or for any other person or entity, or use of our name or trademark, is permitted only with our prior written permission. This report sets forth our findings solely with respect to the test samples identified herein. The results set forth in this report are not indicative or representative of the quality or characteristics of the lot from which a test sample was taken or any similar or identical product unless specifically and expressly noted. Our report includes all of the tests requested by you and the results thereof based upon the information that you provided to us. You have 60 days from date of issuance of this report to notify us of any material error or omission caused by our negligence, provided, however, that such notice shall be in writing and shall specifically address the issue you wish to raise. A failure to raise such issue within the prescribed time shall constitute your unqualified acceptance of the completeness of this report, the tests conducted and the correctness of the report contents. Unless specifically mentioned, the uncertainty of measurement has been explicitly taken into account to declare the compliance or non-compliance to the specification. The report must not be used by the client to claim product certification, approval, or endorsement by TAF or any government agencies.

Table of Contents

Release Control Record	4
1 Certificate of Conformity	5
2 Summary of Test Results	6
2.1 Measurement Uncertainty.....	7
2.2 Modification Record.....	7
3 General Information	8
3.1 Features of EUT.....	8
3.2 General Description of EUT.....	8
3.3 Operating Modes of EUT and Determination of Worst Case Operating Mode.....	8
3.4 Test Program Used and Operation Descriptions.....	9
3.5 Primary Clock Frequencies of Internal Source.....	9
4 Configuration and Connections with EUT	10
4.1 Connection Diagram of EUT and Peripheral Devices.....	10
4.2 Configuration of Peripheral Devices and Cable Connections.....	11
5 Conducted Emission from the AC Mains Power Port	12
5.1 Limits.....	12
5.2 Test Instruments.....	13
5.3 Test Arrangement.....	14
5.4 Test Results.....	15
6 Radiated Emission at Frequencies up to 1GHz	19
6.1 Limits.....	19
6.2 Test Instruments.....	19
6.3 Test Arrangement.....	20
6.4 Test Results.....	21
7 Radiated Emission at Frequencies above 1GHz	23
7.1 Limits.....	23
7.2 Test Instruments.....	24
7.3 Test Arrangement.....	25
7.4 Test Results.....	26
8 General Immunity Requirements	28
8.1 Performance Criteria	29
9 Electrostatic Discharge Immunity Test (ESD)	30
9.1 Test Specification.....	30
9.2 Test Instruments.....	30
9.3 Test Arrangement.....	30
9.4 Test Results.....	32
10 Radiated, Radio-frequency, Electromagnetic Field Immunity Test (RS)	34
10.1 Test Specification.....	34
10.2 Test Instruments.....	34
10.3 Test Arrangement.....	35
10.4 Test Results.....	35
11 Electrical Fast Transient/Burst Immunity Test (EFT)	36
11.1 Test Specification.....	36
11.2 Test Instruments.....	36
11.3 Test Arrangement.....	37

11.4	Test Results.....	37
12	Immunity to Conducted Disturbances Induced by RF Fields (CS).....	38
12.1	Test Specification.....	38
12.2	Test Instruments.....	38
12.3	Test Arrangement.....	39
12.4	Test Results.....	40
13	Power Frequency Magnetic Field Immunity Test	41
13.1	Test Specification.....	41
13.2	Test Instruments.....	41
13.3	Test Arrangement.....	41
13.4	Test Results.....	42
14	Pictures of Test Arrangements.....	43
14.1	Conducted Emission from the AC Mains Power Port.....	43
14.2	Radiated Emission at Frequencies up to 1GHz.....	44
14.3	Radiated Emission at Frequencies above 1GHz.....	45
14.4	Electrostatic Discharge Immunity Test (ESD).....	46
14.5	Radio-frequency, Electromagnetic Field Immunity Test (RS).....	47
14.6	Electrical Fast Transient/Burst Immunity Test (EFT).....	48
14.7	Conducted Disturbances Induced by RF Fields (CS).....	48
14.8	Power Frequency Magnetic Field Immunity Test (PFMF).....	49
	Appendix – Information on the Testing Laboratories.....	50

Release Control Record

Issue No.	Description	Date Issued
CE170627D07	Original release.	Jul. 12, 2017

1 Certificate of Conformity

Product: Low Profile 2-port 10 GigE SFP+ Expansion Card
Brand: Vecow
Test Model: FE-1071
Sample Status: Engineering Sample
Applicant: Vecow Co., Ltd.
Test Date: Jun. 29 ~ Jul. 10, 2017
Standards: **EN 55032:2012 +AC:2013, Class B**
EN 61000-3-2:2014 (Not applicable)
EN 61000-3-3:2013 (Not applicable)
EN 55024:2010
EN 61000-4-2:2009 / IEC 61000-4-2:2008 ED. 2.0
EN 61000-4-3:2006 +A1:2008 +A2:2010 / IEC 61000-4-3:2010 ED. 3.2
EN 61000-4-4:2012 / IEC 61000-4-4:2012 ED. 3.0
EN 61000-4-5:2014 / IEC 61000-4-5:2014 ED. 3.0 (Not applicable)
EN 61000-4-6:2014 / IEC 61000-4-6:2013 ED. 4.0
EN 61000-4-8:2010 / IEC 61000-4-8:2009 ED. 2.0
EN 61000-4-11:2004 / IEC 61000-4-11:2004 ED. 2.0 (Not applicable)

The above equipment has been tested by **Bureau Veritas Consumer Products Services (H.K.) Ltd., Taoyuan Branch**, and found compliance with the requirement of the above standards. The test record, data evaluation & Equipment Under Test (EUT) configurations represented herein are true and accurate accounts of the measurements of the sample's EMC characteristics under the conditions specified in this report.

Prepared by :  , **Date:** Jul. 12, 2017
Vivian Chen / Specialist

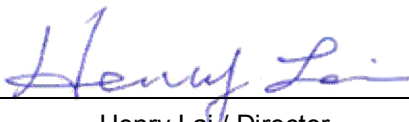
Approved by :  , **Date:** Jul. 12, 2017
Henry Lai / Director

2 Summary of Test Results

Emission			
Standard	Test Item	Result/Remarks	Verdict
EN 55032:2012 +AC:2013	Conducted emission from the AC mains power port	Minimum passing Class B margin is -8.26 dB at 0.18906 MHz	Pass
	Asymmetric mode conducted emission at telecommunication ports	Without telecom port of the EUT	N/A
	Radiated emission 30-1000 MHz	Minimum passing Class B margin is -3.89 dB at 451.89 MHz	Pass
	Radiated emission above 1GHz	Minimum passing Class B margin is -10.99 dB at 1540.02 MHz	Pass
EN 61000-3-2:2014	Harmonic current emissions	Test not applicable because port does not exists	N/A
EN 61000-3-3:2013	Voltage fluctuations and flicker	Test not applicable because port does not exists	N/A

Immunity				
EN 55024 Clause	Basic standard	Test Item	Result/Remarks	Verdict
4.2.1	EN 61000-4-2:2009 / IEC 61000-4-2:2008 ED. 2.0	Electrostatic discharges (ESD)	Performance Criterion B	Pass
4.2.3.2	EN 61000-4-3:2006 +A1:2008 +A2:2010 / IEC 61000-4-3:2010 ED. 3.2	Continuous radiated disturbances (RS)	Performance Criterion A	Pass
4.2.2	EN 61000-4-4:2012 / IEC 61000-4-4:2012 ED. 3.0	Electrical fast transients (EFT)	Performance Criterion A	Pass
4.2.5	EN 61000-4-5:2014 / IEC 61000-4-5:2014 ED. 3.0	Surges	EUT doesn't connect directly to outdoor cables and EUT consumes DC power	N/A
4.2.3.3	EN 61000-4-6:2014 / IEC 61000-4-6:2013 ED. 4.0	Continuous conducted disturbances (CS)	Performance Criterion A	Pass
4.2.4	EN 61000-4-8:2010 / IEC 61000-4-8:2009 ED. 2.0	Power-frequency magnetic fields (PFMF)	Performance Criterion A	Pass
4.2.6	EN 61000-4-11:2004 / IEC 61000-4-11:2004 ED. 2.0	Voltage dips and interruptions	Test not applicable because AC power port does not exist	N/A

Note:

1. There is no deviation to the applied test methods and requirements covered by the scope of this report.
2. The above EN/IEC basic standards are applied with latest version if customer has no special requirement.
3. N/A: Not Applicable

2.1 Measurement Uncertainty

Where relevant, the following measurement uncertainty levels have been estimated for tests performed on the EUT as specified in CISPR 16-4-2:

The listed uncertainties are the worst case uncertainty for the entire range of measurement. Please note that the uncertainty values are provided for informational purposes only and are not used in determining the PASS/FAIL results.

Measurement	Expanded Uncertainty (k=2) (\pm)	Maximum allowable uncertainty (\pm)
Conducted emission from AC mains power port using AMN, 150kHz ~ 30MHz	2.77 dB	3.4 dB (U_{cispr})
Radiated emission, 30MHz ~ 1GHz	3.89 dB	6.3 dB (U_{cispr})
Radiated emission, 1GHz ~ 6GHz	5.12 dB	5.2 dB (U_{cispr})

2.2 Modification Record

There were no modifications required for compliance.

3 General Information

3.1 Features of EUT

The tests reported herein were performed according to the method specified by Vecow Co., Ltd., for detailed feature description, please refer to the manufacturer's specifications or user's manual.

3.2 General Description of EUT

Product	Low Profile 2-port 10 GigE SFP+ Expansion Card
Brand	Vecow
Test Model	FE-1071
Sample Status	Engineering Sample
Operating Software	Win 10
Power Supply Rating	DC power from host equipment
Accessory Device	N/A
Data Cable Supplied	N/A

3.3 Operating Modes of EUT and Determination of Worst Case Operating Mode

1. The EUT was pre-tested under operating and standby condition and the worst emission level was found under **operating condition**.
2. The EUT consumes power from IPC, which designed with AC power supply of rating 100-240Vac, 50/60Hz.
For radiated emission evaluation, 230Vac/50Hz & 110Vac/60Hz had been covered during the pre-test.
The worst data was found at **230Vac/50Hz** and recorded in the applied test report.
3. Test modes are presented in the report as below.

Mode	Test Condition	Input Power (System)
Conducted emission test		
1	EUT with system	230Vac/ 50Hz & 110Vac/ 60Hz
Radiated emission		
1	EUT with system	230Vac/ 50Hz
Immunity tests		
1	EUT with system	230Vac/ 50Hz

3.4 Test Program Used and Operation Descriptions

Emission tests:

- a. Installed the EUT into IPC.
- b. Turned on the power of all equipment.
- c. IPC ran a test program to enable all functions.
- d. IPC read and wrote messages to/ from int. HDD.
- e. IPC sent "color bars with moving element" messages to ext. LCD monitor. Then it displayed "color bar" messages on its screen.
- f. IPC sent messages to printer, and then printer printed it out.
- g. IPC sent messages to modem.
- h. Steps d-g were repeated.

Immunity tests:

- a. Installed the EUT into IPC.
- b. IPC ran a test program to enable all functions.
- c. IPC read and wrote messages to/ from int. HDD.
- d. IPC sent messages to ext. LCD monitor. Then it displayed messages on its screen.
- e. Steps c-d were repeated.

3.5 Primary Clock Frequencies of Internal Source

The highest frequency generated or used within the EUT or on which the EUT operates or tunes is 10GHz, provided by Vecow Co., Ltd., for detailed internal source, please refer to the manufacturer's specifications.

4 Configuration and Connections with EUT

4.1 Connection Diagram of EUT and Peripheral Devices

Emission tests:

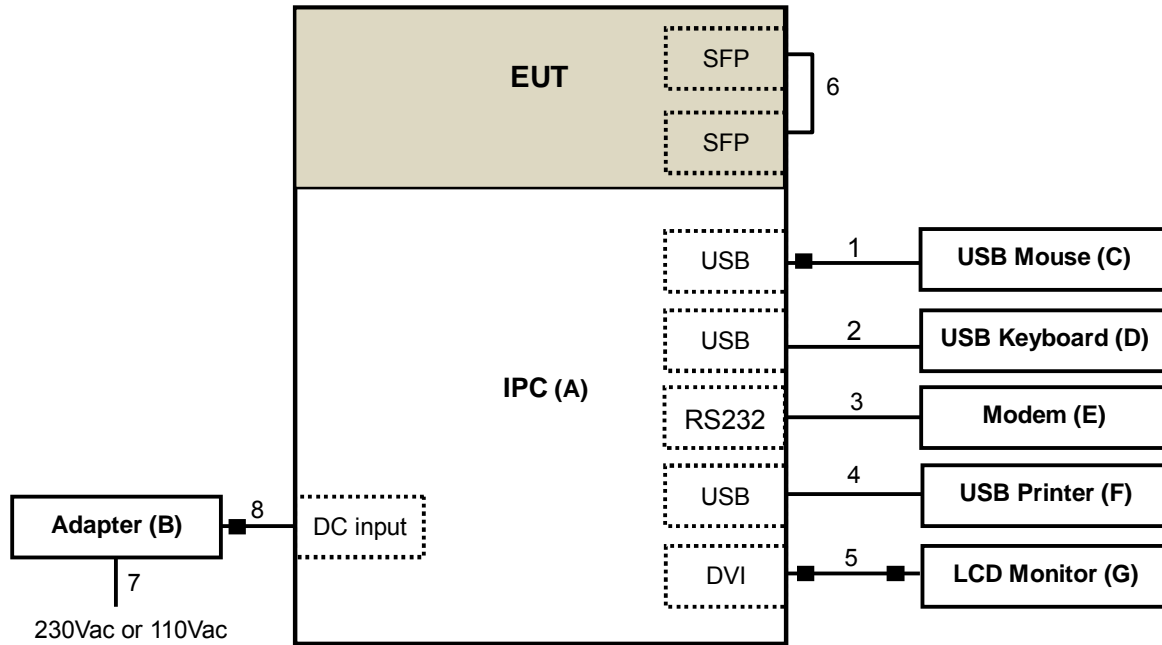

Immunity tests:

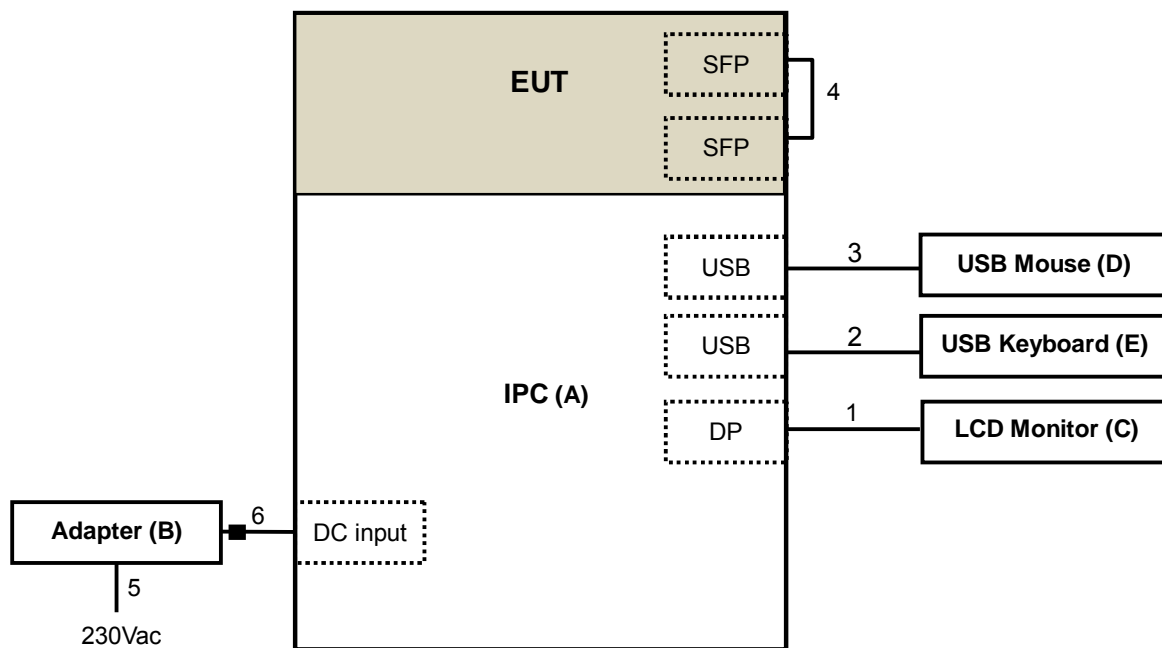

4.2 Configuration of Peripheral Devices and Cable Connections

Emission tests:

ID	Product	Brand	Model No.	Serial No.	FCC ID	Remarks
A.	IPC	VECOW	RCS-9440	N/A	N/A	Supplied by client
B.	Adapter	MW	GS160A24	N/A	N/A	Supplied by client
C.	USB Mouse	Microsoft	1113	9170515772224	FCC DOC Approved	Provided by Lab
D.	USB KEYBOARD	BTC	5200U	G09302046627	E5XKB5122U	Provided by Lab
E.	MODEM	ACEEX	1414	980020512	IFAXDM1414	Provided by Lab
F.	PRINTER	HP	CV136-64001	CN55FCV012	B94SDGOB1191	Provided by Lab
G.	24" LCD MONITOR	DELL	U2410	CN082WXD728720 CC0KVL	FCC DoC Approved	Provided by Lab

Note: All power cords of the above support units are non-shielded (1.8m).

ID	Descriptions	Qty.	Length (m)	Shielding (Yes/No)	Cores (Qty.)	Remarks
1.	USB cable	1	1.8	Y	1	Provided by Lab
2.	USB cable	1	1.8	Y	0	Provided by Lab
3.	RS232 cable	1	1.2	Y	0	Provided by Lab
4.	USB cable	1	1.5	Y	0	Provided by Lab
5.	DVI cable	1	1.8	Y	2	Provided by Lab
6.	Coaxial cable	1	1.2	Y	0	Provided by Lab
7.	AC power cable	1	1.8	N	0	Supplied by client
8.	DC power cable	1	1.15	N	1	Supplied by client

Note: The core(s) is(are) originally attached to the cable(s).

Immunity tests:

ID	Product	Brand	Model No.	Serial No.	FCC ID	Remarks
A.	IPC	VECOW	RCS-9440	N/A	N/A	Supplied by client
B.	Adapter	MW	GS160A24	N/A	N/A	Supplied by client
C.	24" LCD MONITOR	DELL	U2413f	CN-06VNX5-72872-4 6D-A88L	FCC DoC Approved	Provided by Lab
D.	USB MOUSE	HP	M-UAE96	F93A90AN3V42GO7	FCC DoC Approved	Provided by Lab
E.	USB KEYBOARD	HP	KUS0133	CN-0J4635-71616-63 I-076F	FCC DoC Approved	Provided by Lab

Note: All power cords of the above support units are non-shielded (1.8m).

ID	Descriptions	Qty.	Length (m)	Shielding (Yes/No)	Cores (Qty.)	Remarks
1.	Display cable	1	1.8	Y	0	Provided by Lab
2.	USB cable	1	1.8	Y	0	Provided by Lab
3.	USB cable	1	1.8	Y	0	Provided by Lab
4.	SFP cable	1	3.2	N	0	Provided by Lab
5.	AC power cable	1	1.8	N	0	Supplied by client
6.	DC power cable	1	1.15	N	1	Supplied by client

Note: The core(s) is(are) originally attached to the cable(s).

5 Conducted Emission from the AC Mains Power Port

5.1 Limits

Frequency range (MHz)	Coupling device	Detector type / bandwidth	Class A limits (dBuV)
0.15 - 0.5	AMN	Quasi-peak / 9kHz	79
0.5 - 30.0			73
0.15 - 0.5		Average / 9kHz	66
0.5 - 30.0			60

Frequency range (MHz)	Coupling device	Detector type / bandwidth	Class B limits (dBuV)
0.15 - 0.5	AMN	Quasi-peak / 9kHz	66 - 56
0.5 - 5			56
5 - 30.0			60
0.15 - 0.5		Average / 9kHz	56 - 46
0.5 - 5			46
5 - 30.0			50

5.2 Test Instruments

Description & Manufacturer	Model No.	Serial No.	Cal. Date	Cal. Due
ROHDE & SCHWARZ TEST RECEIVER	ESCS 30	100290	Dec. 26, 2016	Dec. 25, 2017
ROHDE & SCHWARZ Artificial Mains Network (for EUT)	ESH2-Z5	100104	Dec. 01, 2016	Nov. 30, 2017
LISN With Adapter (for EUT)	AD10	C09Ada-001	Dec. 01, 2016	Nov. 30, 2017
ROHDE & SCHWARZ Artificial Mains Network (for peripherals)	ESH3-Z5	847265/023	Oct. 27, 2016	Oct. 26, 2017
SCHWARZBECK Artificial Mains Network (For EUT)	NNLK8129	8129229	May 09, 2017	May 08, 2018
Software	Cond_V7.3.7.4	NA	NA	NA
RF cable (JYEBAO) With 10dB PAD	5D-FB	Cable-C09.01	Feb. 21, 2017	Feb. 20, 2018
SUHNER Terminator (For ROHDE & SCHWARZ LISN)	65BNC-5001	E1-010789	May 18, 2017	May 17, 2018
ROHDE & SCHWARZ Artificial Mains Network (For TV EUT)	ESH3-Z5	100220	Nov. 08, 2016	Nov. 07, 2017
LISN With Adapter (for TV EUT)	100220	N/A	Nov. 08, 2016	Nov. 07, 2017

- Notes:
1. The calibration interval of the above test instruments is 12 months and the calibrations are traceable to NML/ROC and NIST/USA.
 2. The test was performed in Shielded Room No. 9.
 3. The VCCI Site Registration No. C-1312.
 4. Tested Date: Jun. 29, 2017

5.3 Test Arrangement

- The EUT was placed 0.4 meters from the conducting wall of the shielded room with EUT being connected to the power mains through an Artificial Mains Network (AMN). Other support units were connected to the power mains through another AMN. The two AMNs provide 50 Ohm/ 50uH of coupling impedance for the measuring instrument.
- Both lines of the power mains connected to the EUT were checked for maximum conducted interference.
- The test results of conducted emissions at mains ports are recorded of six worst margins for quasi-peak (mandatory) [and average (if necessary)] values against the limits at frequencies of interest unless the margin is 20 dB or greater.

Note: The resolution bandwidth and video bandwidth of test receiver is 9kHz for quasi-peak detection (QP) and average detection (AV) at frequency 0.15MHz-30MHz.

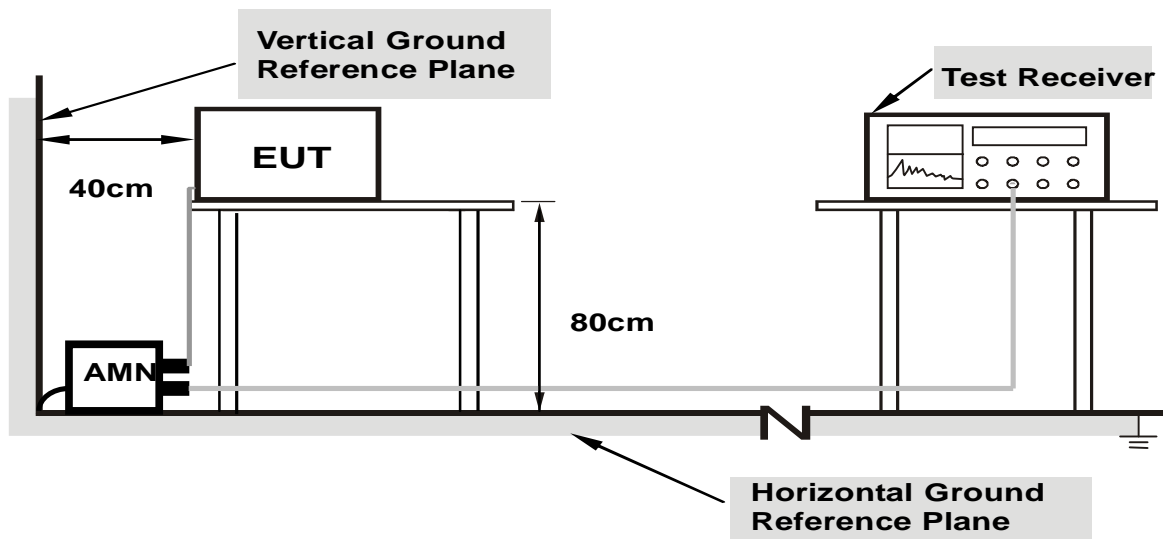

- Note:**
- Support units were connected to second AMN.
 - The distance specified between EUT/AE and other metallic objects is ≥ 0.8 m in the measurement arrangement for table-top EUT.
 - Cable on the RGP must to be insulated.

For the actual test configuration, please refer to the related item – Photographs of the Test Configuration.

5.4 Test Results

Frequency Range	150kHz ~ 30MHz	Detector Function & Bandwidth	Quasi-Peak (QP) / Average (AV), 9kHz
Input Power (System)	110Vac, 60Hz	Environmental Conditions	24°C, 77%RH, 1001mbar
Tested by	Chiawei Lin		
Test Mode	Mode 1		

Phase Of Power : Line (L)										
No	Frequency (MHz)	Correction Factor (dB)	Reading Value (dBuV)		Emission Level (dBuV)		Limit (dBuV)		Margin (dB)	
			Q.P.	AV.	Q.P.	AV.	Q.P.	AV.	Q.P.	AV.
1	0.16172	10.09	30.65	7.78	40.74	17.87	65.38	55.38	-24.64	-37.51
2	0.18906	10.10	40.47	35.72	50.57	45.82	64.08	54.08	-13.51	-8.26
3	0.25156	10.13	24.81	13.20	34.94	23.33	61.71	51.71	-26.77	-28.38
4	0.81016	10.23	19.57	12.63	29.80	22.86	56.00	46.00	-26.20	-23.14
5	10.88281	10.75	15.67	8.89	26.42	19.64	60.00	50.00	-33.58	-30.36
6	23.94141	11.12	22.85	15.25	33.97	26.37	60.00	50.00	-26.03	-23.63

Remarks:

1. Q.P. and AV. are abbreviations of quasi-peak and average individually.
2. The emission levels of other frequencies were very low against the limit.
3. Margin value = Emission level – Limit value
4. Correction factor = Insertion loss + Cable loss
5. Emission Level = Correction Factor + Reading Value

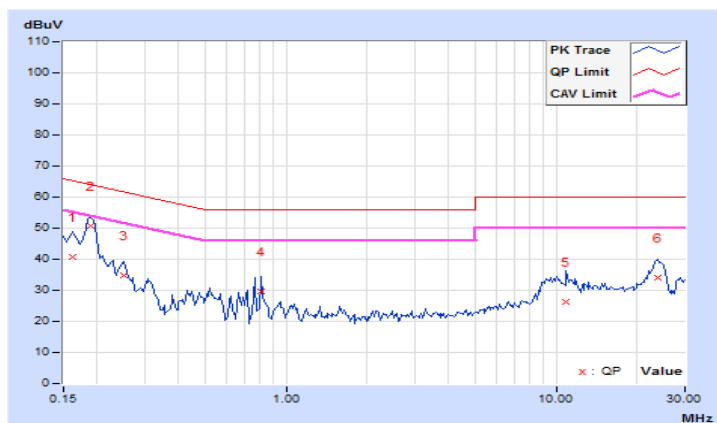

Frequency Range	150kHz ~ 30MHz	Detector Function & Bandwidth	Quasi-Peak (QP) / Average (AV), 9kHz
Input Power (System)	110Vac, 60Hz	Environmental Conditions	24°C, 77%RH, 1001mbar
Tested by	Chiawei Lin		
Test Mode	Mode 1		

Phase Of Power : Neutral (N)										
No	Frequency (MHz)	Correction Factor (dB)	Reading Value (dBuV)		Emission Level (dBuV)		Limit (dBuV)		Margin (dB)	
			Q.P.	AV.	Q.P.	AV.	Q.P.	AV.	Q.P.	AV.
1	0.19297	10.05	39.56	33.15	49.61	43.20	63.91	53.91	-14.30	-10.71
2	0.24766	10.07	24.69	10.81	34.76	20.88	61.84	51.84	-27.08	-30.96
3	0.31016	10.11	23.52	18.01	33.63	28.12	59.97	49.97	-26.34	-21.85
4	0.81016	10.29	18.34	11.20	28.63	21.49	56.00	46.00	-27.37	-24.51
5	9.62500	10.68	15.96	10.08	26.64	20.76	60.00	50.00	-33.36	-29.24
6	24.32422	10.67	20.87	13.20	31.54	23.87	60.00	50.00	-28.46	-26.13

Remarks:

1. Q.P. and AV. are abbreviations of quasi-peak and average individually.
2. The emission levels of other frequencies were very low against the limit.
3. Margin value = Emission level – Limit value
4. Correction factor = Insertion loss + Cable loss
5. Emission Level = Correction Factor + Reading Value

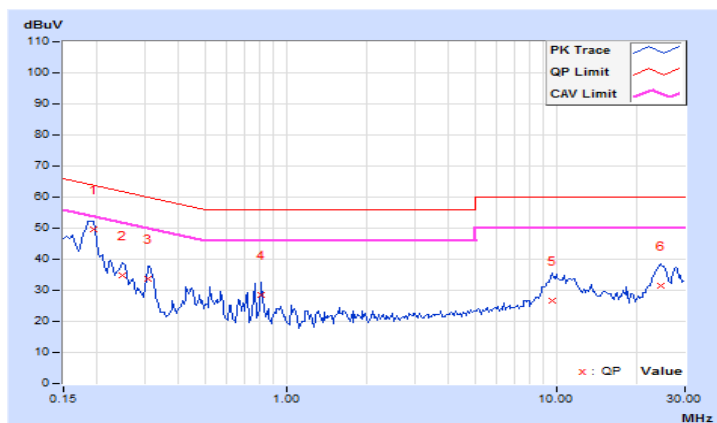

Frequency Range	150kHz ~ 30MHz	Detector Function & Bandwidth	Quasi-Peak (QP) / Average (AV), 9kHz
Input Power (System)	230Vac, 50Hz	Environmental Conditions	24°C, 77%RH, 1001mbar
Tested by	Chiawei Lin		
Test Mode	Mode 1		

Phase Of Power : Line (L)										
No	Frequency (MHz)	Correction Factor (dB)	Reading Value (dBuV)		Emission Level (dBuV)		Limit (dBuV)		Margin (dB)	
			Q.P.	AV.	Q.P.	AV.	Q.P.	AV.	Q.P.	AV.
1	0.16562	10.09	29.00	8.71	39.09	18.80	65.18	55.18	-26.09	-36.38
2	0.18906	10.10	40.49	35.72	50.59	45.82	64.08	54.08	-13.49	-8.26
3	0.25156	10.13	24.73	13.00	34.86	23.13	61.71	51.71	-26.85	-28.58
4	0.81016	10.23	19.92	12.69	30.15	22.92	56.00	46.00	-25.85	-23.08
5	10.34766	10.73	17.87	13.47	28.60	24.20	60.00	50.00	-31.40	-25.80
6	24.41406	11.12	22.62	14.76	33.74	25.88	60.00	50.00	-26.26	-24.12

Remarks:

1. Q.P. and AV. are abbreviations of quasi-peak and average individually.
2. The emission levels of other frequencies were very low against the limit.
3. Margin value = Emission level – Limit value
4. Correction factor = Insertion loss + Cable loss
5. Emission Level = Correction Factor + Reading Value

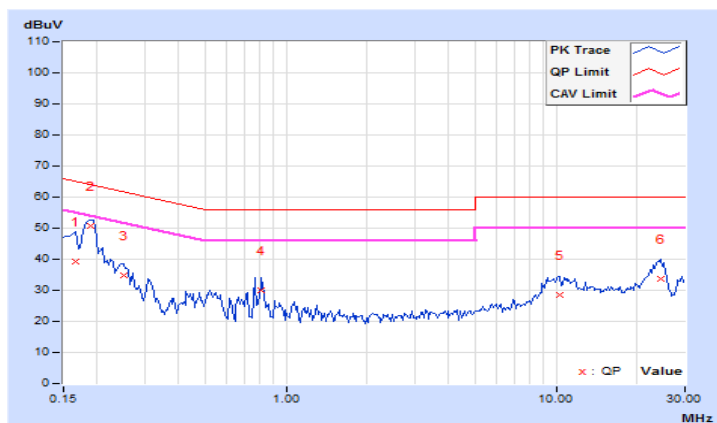

Frequency Range	150kHz ~ 30MHz	Detector Function & Bandwidth	Quasi-Peak (QP) / Average (AV), 9kHz
Input Power (System)	230Vac, 50Hz	Environmental Conditions	24°C, 77%RH, 1001mbar
Tested by	Chiawei Lin		
Test Mode	Mode 1		

Phase Of Power : Neutral (N)										
No	Frequency (MHz)	Correction Factor (dB)	Reading Value (dBuV)		Emission Level (dBuV)		Limit (dBuV)		Margin (dB)	
			Q.P.	AV.	Q.P.	AV.	Q.P.	AV.	Q.P.	AV.
1	0.16562	10.08	29.40	9.01	39.48	19.09	65.18	55.18	-25.70	-36.09
2	0.19042	10.05	39.86	35.43	49.91	45.48	64.02	54.02	-14.11	-8.54
3	0.31016	10.11	23.52	18.39	33.63	28.50	59.97	49.97	-26.34	-21.47
4	0.81016	10.29	18.30	11.95	28.59	22.24	56.00	46.00	-27.41	-23.76
5	10.07031	10.69	15.79	9.79	26.48	20.48	60.00	50.00	-33.52	-29.52
6	24.84766	10.65	20.91	13.88	31.56	24.53	60.00	50.00	-28.44	-25.47

Remarks:

1. Q.P. and AV. are abbreviations of quasi-peak and average individually.
2. The emission levels of other frequencies were very low against the limit.
3. Margin value = Emission level – Limit value
4. Correction factor = Insertion loss + Cable loss
5. Emission Level = Correction Factor + Reading Value

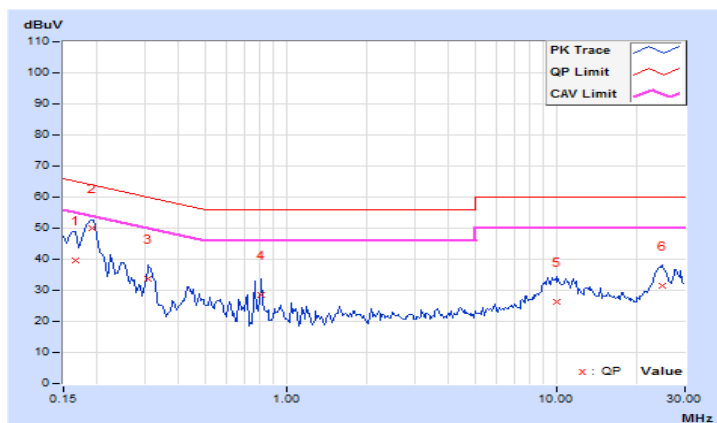

6 Radiated Emission at Frequencies up to 1GHz

6.1 Limits

For Class A Equipment

Frequency range (MHz)	Distance (m)	Limits (dBuV/m)
30 - 230	10	40
230 - 1000		47
30 - 230	3	50
230 - 1000		57

For Class B Equipment

Frequency range (MHz)	Distance (m)	Limits (dBuV/m)
30 - 230	10	30
230 - 1000		37
30 - 230	3	40
230 - 1000		47

6.2 Test Instruments

Description & Manufacturer	Model No.	Serial No.	Cal. Date	Cal. Due
ROHDE & SCHWARZ TEST RECEIVER	ESCI	100412	Sep. 05, 2016	Sep. 04, 2017
Schwarzbeck BILOG Antenna	VULB9168	9168-479	Dec. 16, 2016	Dec. 15, 2017
Agilent Preamplifier	8447D	2944A08312	Feb. 21, 2017	Feb. 20, 2018
CT Turn Table	TT100	CT-0055	NA	NA
CT Tower	AT100	CT-0055	NA	NA
Software	Radiated_V7.6.15.9.5	NA	NA	NA
ADT RF Switches BOX	EM-H-01-1	1002	Sep. 22 2016	Sep. 21, 2017
WOKEN RF cable With 5dB PAD	8D	CABLE-ST6-01	Sep. 22 2016	Sep. 21, 2017

Notes: 1. The calibration interval of the above test instruments is 12 months and the calibrations are traceable to NML/ROC and NIST/USA.

2. The test was performed in Open Site No. 6.

3. The VCCI Site Registration No. R-728.

4. The FCC Site Registration No. 90427.

5. Tested Date: Jul. 4, 2017

6.3 Test Arrangement

- The EUT was placed on the top of a rotating table 0.8 meters above the ground at an accredited test facility. The table was rotated 360 degrees to determine the position of the highest radiation.
- The EUT was set 10 meters away from the interference-receiving antenna, which was mounted on the top of a variable-height antenna tower.
- The antenna is a broadband antenna, and its height is varied from one meter to four meters above the ground to determine the maximum value of the field strength. Both horizontal and vertical polarizations of the antenna are set to make the measurement.
- For each suspected emission, the EUT was arranged to its worst case and then the antenna was tuned to heights from 1 meter to 4 meters and the rotatable table was turned from 0 degrees to 360 degrees to find the maximum reading.
- The test-receiver system was set to quasi-peak detect function and specified bandwidth with maximum hold mode when the test frequency is up to 1 GHz.

Note:

- The resolution bandwidth and video bandwidth of test receiver/spectrum analyzer is 120kHz for quasi-peak detection (QP) at frequency up to 1GHz.
- The measurement distance is the shortest horizontal distance between an imaginary circular periphery just encompassing this arrangement and the calibration point of the antenna.

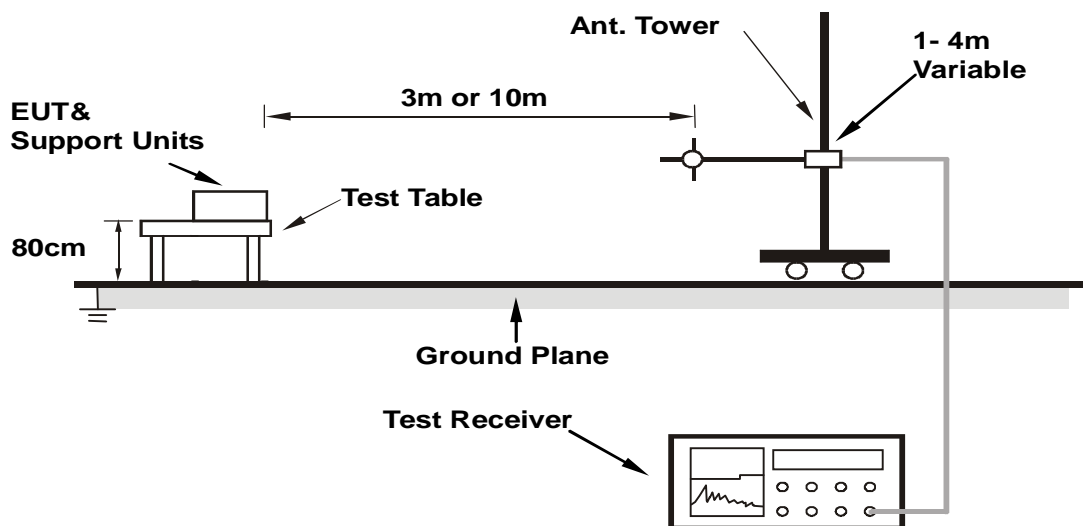

Note: Cable on the RGP must be insulated.

For the actual test configuration, please refer to the related item – Photographs of the Test Configuration.

6.4 Test Results

Frequency Range	30MHz ~ 1GHz	Detector Function & Bandwidth	Quasi-Peak (QP), 120kHz
Tested by	Vincent Lin	Environmental Conditions	33°C, 58%RH, 1002mbar
Test Mode	Mode 1		

Antenna Polarity & Test Distance : Horizontal at 10 m								
No	Frequency (MHz)	Emission Level (dBuV/m)	Limit (dBuV/m)	Margin (dB)	Antenna Height (m)	Table Angle (Degree)	Raw Value (dBuV)	Correction Factor (dB/m)
1	125.00	25.47 QP	30.00	-4.53	4.00 H	98	36.31	-10.84
2	132.71	25.33 QP	30.00	-4.67	4.00 H	150	35.52	-10.19
3	159.24	25.26 QP	30.00	-4.74	4.00 H	212	34.02	-8.76
4	229.95	23.15 QP	30.00	-6.85	4.00 H	283	34.17	-11.02
5	431.59	32.91 QP	37.00	-4.09	2.82 H	37	37.24	-4.33
6	451.89	33.11 QP	37.00	-3.89	2.25 H	301	37.24	-4.13
7	623.51	30.66 QP	37.00	-6.34	1.39 H	61	31.06	-0.40
8	979.32	32.87 QP	37.00	-4.13	1.33 H	242	27.01	5.86
9	999.86	32.09 QP	37.00	-4.91	1.00 H	36	25.87	6.22

Remarks:

1. Emission Level(dBuV/m) = Raw Value(dBuV) + Correction Factor(dB/m)
2. Correction Factor(dB/m) = Antenna Factor (dB/m) + Cable Factor (dB) – Pre-Amplifier Factor (dB)
3. The other emission levels were very low against the limit.
4. Margin value = Emission level – Limit value

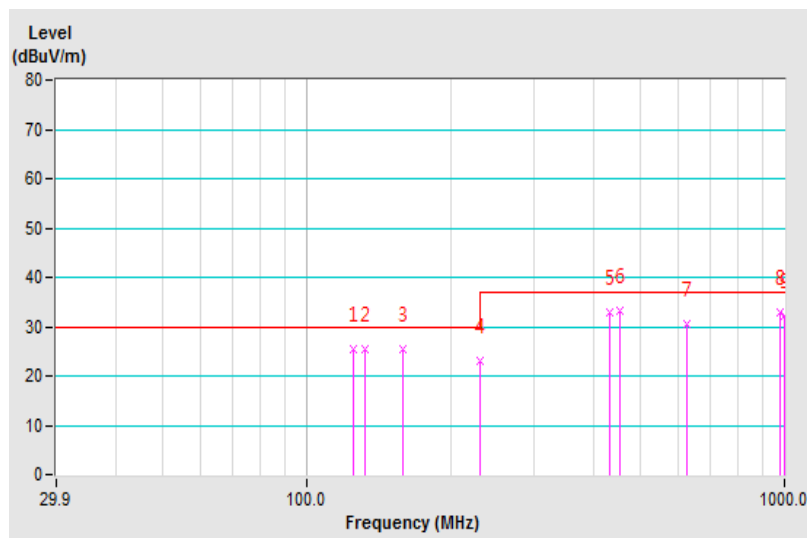

Frequency Range	30MHz ~ 1GHz	Detector Function & Bandwidth	Quasi-Peak (QP), 120kHz
Tested by	Vincent Lin	Environmental Conditions	33°C, 58%RH, 1002mbar
Test Mode	Mode 1		

Antenna Polarity & Test Distance : Vertical at 10 m								
No	Frequency (MHz)	Emission Level (dBuV/m)	Limit (dBuV/m)	Margin (dB)	Antenna Height (m)	Table Angle (Degree)	Raw Value (dBuV)	Correction Factor (dB/m)
1	44.75	22.45 QP	30.00	-7.55	1.00 V	43	32.03	-9.58
2	103.00	25.70 QP	30.00	-4.30	1.00 V	146	39.09	-13.39
3	125.01	25.69 QP	30.00	-4.31	1.00 V	248	36.52	-10.83
4	132.71	25.05 QP	30.00	-4.95	1.00 V	226	35.24	-10.19
5	166.87	25.17 QP	30.00	-4.83	1.00 V	177	34.39	-9.22
6	222.68	22.39 QP	30.00	-7.61	1.00 V	123	33.82	-11.43
7	280.15	30.04 QP	37.00	-6.96	1.00 V	64	37.90	-7.86
8	399.57	31.66 QP	37.00	-5.34	1.00 V	197	37.00	-5.34
9	642.25	29.84 QP	37.00	-7.16	2.93 V	102	30.07	-0.23
10	986.50	32.08 QP	37.00	-4.92	2.59 V	250	26.12	5.96

Remarks:

1. Emission Level(dBuV/m) = Raw Value(dBuV) + Correction Factor(dB/m)
2. Correction Factor(dB/m) = Antenna Factor (dB/m) + Cable Factor (dB) – Pre-Amplifier Factor (dB)
3. The other emission levels were very low against the limit.
4. Margin value = Emission level – Limit value

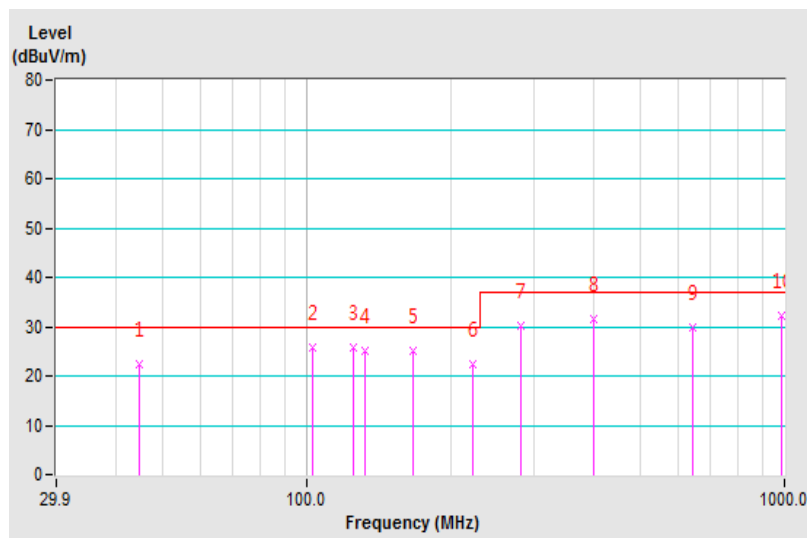

7 Radiated Emission at Frequencies above 1GHz

7.1 Limits

For Class A Equipment

Frequency range (MHz)	Distance (m)	Detector type	Limits (dBuV/m)
1000 - 3000	3	Average	56
3000 - 6000			60
1000 - 3000		Peak	76
3000 - 6000			80

For Class B Equipment

Frequency range (MHz)	Distance (m)	Detector type	Limits (dBuV/m)
1000 - 3000	3	Average	50
3000 - 6000			54
1000 - 3000		Peak	70
3000 - 6000			74

Required highest frequency for radiated measurement

Highest internal frequency (F_x)	Highest measured frequency
$F_x \leq 108$ MHz	1 GHz
108 MHz $< F_x \leq 500$ MHz	2 GHz
500 MHz $< F_x \leq 1$ GHz	5 GHz
$F_x > 1$ GHz	$5 \times F_x$ up to a maximum of 6 GHz

NOTE 1 For FM and TV broadcast receivers, F_x is determined from the highest frequency generated or used excluding the local oscillator and tuned frequencies.

NOTE 2 F_x is highest fundamental frequency generated or used within the EUT or highest frequency at which it operates.

Where F_x is unknown, the radiated emission measurements shall be performed up to 6 GHz.

7.2 Test Instruments

Description & Manufacturer	Model No.	Serial No.	Cal. Date	Cal. Due
Agilent Spectrum	E4446A	MY51100009	Jun. 01, 2017	May 31, 2018
Agilent Test Receiver	N9038A	MY50010135	Jun. 29, 2017	Jun. 28, 2018
Agilent Preamplifier	8449B	3008A02367	Feb. 22, 2017	Feb. 21, 2018
MITEQ Preamplifier	AMF-6F-260400-33-8P	892164	Feb. 21, 2017	Feb. 20, 2018
EMCI Preamplifier	EMC184045B	980235	Feb. 22, 2017	Feb. 21, 2018
Schwarzbeck Horn Antenna	BBHA-9170	212	Dec. 30, 2016	Dec. 29, 2017
EMCO Horn Antenna	3115	9312-4192	Dec. 28, 2016	Dec. 27, 2017
Max Full. Turn Table & Tower	MF7802	MF780208103	NA	NA
Software	Radiated_V8.7.08	NA	NA	NA
SUHNER RF cable With 4dB PAD	SF106-18	Cable-CH7	Aug. 15, 2016	Aug. 14, 2017
SUHNER RF cable With 3/4dB PAD	SF102	Cable-CH7-3.6m	Aug. 15, 2016	Aug. 14, 2017
MICRO-TRONICS Notch filter	BRC50703-01	010	May 31, 2017	May 30, 2018
MICRO-TRONICS Band Pass Filter	BRM17690	005	May 31, 2017	May 30, 2018

- Notes:
1. The calibration interval of the above test instruments is 12 months and the calibrations are traceable to NML/ROC and NIST/USA.
 2. The 3dB beamwidth of the horn antenna is minimum 30 degree (or $w = 1.6m$ at 3m distance) for 1~6 GHz.
 3. The test was performed in Chamber No. 7.
 4. The Industry Canada Reference No. IC 7450E-7.
 5. The FCC Site Registration No. 127748.
 6. The VCCI Site Registration No. G-39.
 7. Tested Date: Jun. 30, 2017

7.3 Test Arrangement

- The EUT was placed on the top of a rotating table 0.8 meters above the ground at an accredited chamber room. The table was rotated 360 degrees to determine the position of the highest radiation.
- The EUT was set 3 meters away from the interference-receiving antenna, which was mounted on the top of a variable-height antenna tower.
- The height of antenna can be varied from one meter to four meters, the height of adjustment depends on the EUT height and the antenna 3dB beamwidth both, to detect the maximum value of the field strength. Both horizontal and vertical polarizations of the antenna are set to make the measurement.
- For each suspected emission, the EUT was arranged to its worst case and then the antenna was tuned to heights and the rotatable table was turned from 0 degrees to 360 degrees to find the maximum reading.
- The spectrum analyzer system was set to peak and average detect function and specified bandwidth with maximum hold mode when the test frequency is above 1 GHz.

Note:

- The resolution bandwidth of test receiver/spectrum analyzer is 1MHz and video bandwidth is 3MHz for Peak detection (PK) at frequency above 1GHz. The resolution bandwidth of test receiver/spectrum analyzer is 1 MHz for Average detection (AV) at frequency above 1GHz.
- The measurement distance is the shortest horizontal distance between an imaginary circular periphery just encompassing this arrangement and the calibration point of the antenna.

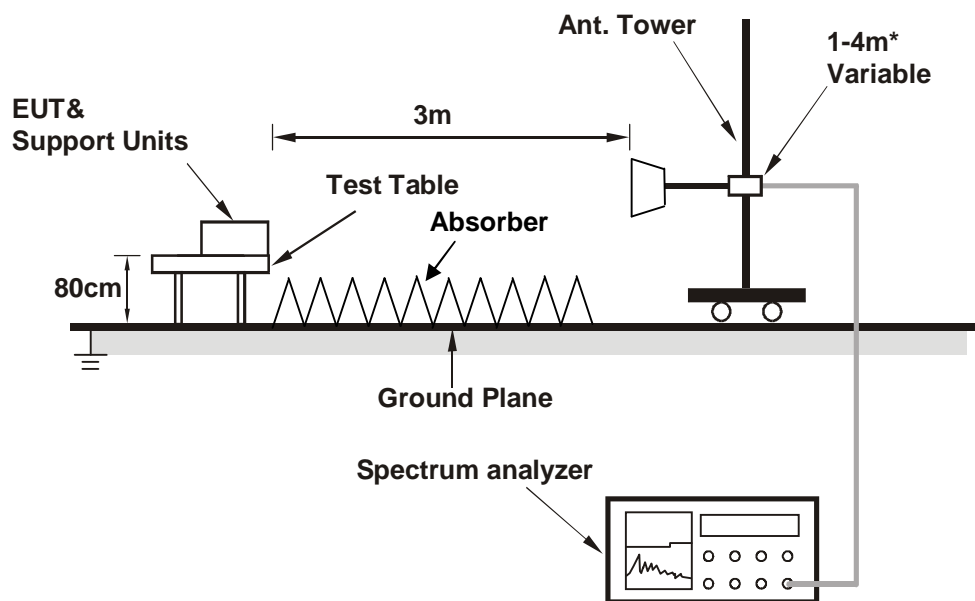

Note: Cable on the RGP must to be insulated.

* :depends on the EUT height and the antenna 3dB beamwidth both.

For the actual test configuration, please refer to the related item – Photographs of the Test Configuration.

7.4 Test Results

Frequency Range	1GHz ~ 6GHz	Detector Function & Bandwidth	Peak (PK) / Average (AV), 1MHz
Tested by	Paul Chen	Environmental Conditions	25°C, 75%RH, 1001mbar
Test Mode	Mode 1		

Antenna Polarity & Test Distance : Horizontal at 3 m								
No	Frequency (MHz)	Emission Level (dBuV/m)	Limit (dBuV/m)	Margin (dB)	Antenna Height (m)	Table Angle (Degree)	Raw Value (dBuV)	Correction Factor (dB/m)
1	1066.64	44.73 PK	70.00	-25.27	1.44 H	53	47.61	-2.88
2	1066.64	29.82 AV	50.00	-20.18	1.44 H	53	32.70	-2.88
3	1374.93	43.44 PK	70.00	-26.56	1.13 H	224	45.84	-2.40
4	1374.93	33.39 AV	50.00	-16.61	1.13 H	224	35.79	-2.40
5	1540.02	49.30 PK	70.00	-20.70	1.09 H	210	51.61	-2.31
6	1540.02	39.01 AV	50.00	-10.99	1.09 H	210	41.32	-2.31
7	1868.37	42.21 PK	70.00	-27.79	2.41 H	254	42.91	-0.70
8	1868.37	29.25 AV	50.00	-20.75	2.41 H	254	29.95	-0.70
9	2127.17	51.78 PK	70.00	-18.22	1.55 H	130	51.71	0.07
10	2127.17	32.01 AV	50.00	-17.99	1.55 H	130	31.94	0.07
11	2325.54	43.33 PK	70.00	-26.67	1.48 H	325	43.16	0.17
12	2325.54	30.26 AV	50.00	-19.74	1.48 H	325	30.09	0.17

Remarks:

1. Emission Level(dBuV/m) = Raw Value(dBuV) + Correction Factor(dB/m)
2. Correction Factor(dB/m) = Antenna Factor (dB/m) + Cable Factor (dB) – Pre-Amplifier Factor (dB)
3. The other emission levels were very low against the limit.
4. Margin value = Emission level – Limit value

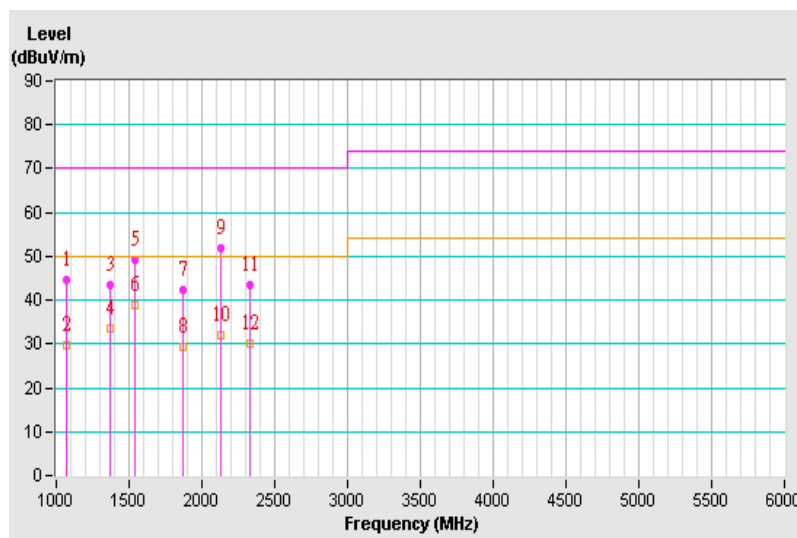

Frequency Range	1GHz ~ 6GHz	Detector Function & Bandwidth	Peak (PK) / Average (AV), 1MHz
Tested by	Paul Chen	Environmental Conditions	25°C, 75%RH, 1001mbar
Test Mode	Mode 1		

Antenna Polarity & Test Distance : Vertical at 3 m								
No	Frequency (MHz)	Emission Level (dBuV/m)	Limit (dBuV/m)	Margin (dB)	Antenna Height (m)	Table Angle (Degree)	Raw Value (dBuV)	Correction Factor (dB/m)
1	1062.74	44.21 PK	70.00	-25.79	1.43 V	170	47.09	-2.88
2	1062.74	29.66 AV	50.00	-20.34	1.43 V	170	32.54	-2.88
3	1328.74	42.63 PK	70.00	-27.37	2.07 V	193	45.46	-2.83
4	1328.74	27.48 AV	50.00	-22.52	2.07 V	193	30.31	-2.83
5	1539.86	47.39 PK	70.00	-22.61	1.47 V	14	49.70	-2.31
6	1539.86	36.87 AV	50.00	-13.13	1.47 V	14	39.18	-2.31
7	2129.39	49.32 PK	70.00	-20.68	1.52 V	176	49.25	0.07
8	2129.39	31.28 AV	50.00	-18.72	1.52 V	176	31.21	0.07
9	2406.13	47.69 PK	70.00	-22.31	1.00 V	272	47.52	0.17
10	2406.13	30.47 AV	50.00	-19.53	1.00 V	272	30.30	0.17
11	2664.98	48.21 PK	70.00	-21.79	1.55 V	155	45.69	2.52
12	2664.98	31.90 AV	50.00	-18.10	1.55 V	155	29.38	2.52

Remarks:

1. Emission Level(dBuV/m) = Raw Value(dBuV) + Correction Factor(dB/m)
2. Correction Factor(dB/m) = Antenna Factor (dB/m) + Cable Factor (dB) – Pre-Amplifier Factor (dB)
3. The other emission levels were very low against the limit.
4. Margin value = Emission level – Limit value

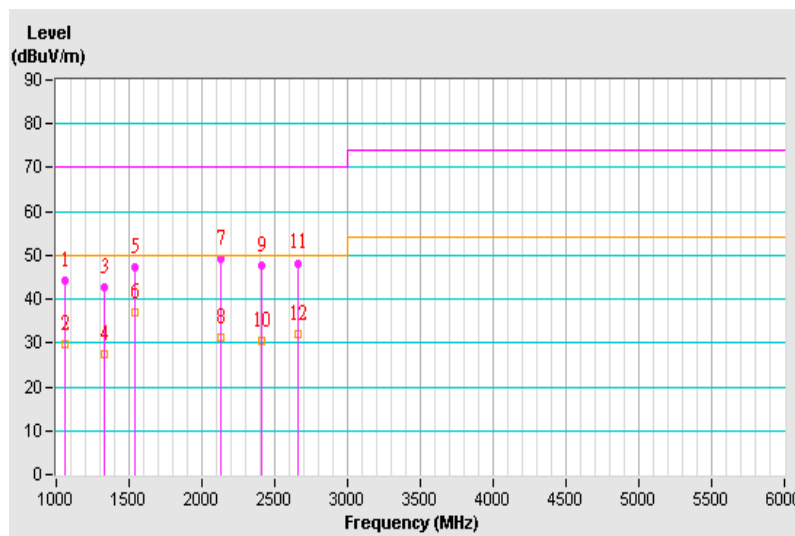

8 General Immunity Requirements

EN 55024:2010, Immunity requirements

Clause	Reference standard	Table	Test specification	Performance Criterion
4.2.1	EN/IEC 61000-4-2 ESD	1.3	Enclosure port: ±8kV Air discharge, ±4kV Contact discharge	B
4.2.3.2	EN/IEC 61000-4-3 RS	1.2	Enclosure port: 80-1000 MHz, 3V/m, 80% AM (1kHz)	A
4.2.2	EN/IEC 61000-4-4 EFT	2.3	Signal ports and telecommunication ports: xDSL equipment: ±0.5kV, 5/50 (T _r /T _h) ns, 100kHz others: ±0.5kV, 5/50 (T _r /T _h) ns, 5kHz	B
		3.3	Input DC power port: ±0.5kV, 5/50 (T _r /T _h) ns, 5kHz	
		4.5	Input AC Power ports: ±1kV, 5/50 (T _r /T _h) ns, 5kHz	
4.2.3.3	EN/IEC 61000-4-6 CS	2.1	Signal and telecommunication ports(cable length > 3m): 0.15-80 MHz, 3V, 80% AM (1kHz)	A
		3.1	Input DC power port: 0.15-80 MHz, 3V, 80% AM (1kHz)	
		4.1	Input AC Power ports: 0.15-80 MHz, 3V, 80% AM (1kHz)	
4.2.4	EN/IEC 61000-4-8 PFMF	1.1	Enclosure port: 50 or 60 Hz, 1A/m	A

8.1 Performance Criteria

General Performance Criteria

Performance criterion A

The equipment shall continue to operate as intended without operator intervention. No degradation of performance or loss of function is allowed below a performance level specified by the manufacturer when the equipment is used as intended. The performance level may be replaced by a permissible loss of performance. If the minimum performance level or the permissible performance loss is not specified by the manufacturer, then either of these may be derived from the product description and documentation, and by what the user may reasonably expect from the equipment if used as intended.

Performance criterion B

After the test, the equipment shall continue to operate as intended without operator intervention. No degradation of performance or loss of function is allowed, after the application of the phenomena below a performance level specified by the manufacturer, when the equipment is used as intended. The performance level may be replaced by a permissible loss of performance. During the test, degradation of performance is allowed. However, no change of operating state or stored data is allowed to persist after the test. If the minimum performance level (or the permissible performance loss) is not specified by the manufacturer, then either of these may be derived from the product description and documentation, and by what the user may reasonably expect from the equipment if used as intended.

Performance criterion C

Loss of function is allowed, provided the function is self-recoverable, or can be restored by the operation of the controls by the user in accordance with the manufacturer's instructions. Functions, and/or information stored in non-volatile memory, or protected by a battery backup, shall not be lost.

Particular performance criteria

The particular performance criteria which are specified in the normative annexes of EN 55024 take precedence over the corresponding parts of the general performance criteria. Where particular performance criteria for specific functions are not given, then the general performance criteria shall apply.

9 Electrostatic Discharge Immunity Test (ESD)

9.1 Test Specification

Basic Standard:	EN/IEC 61000-4-2
Discharge Impedance:	330 ohm / 150 pF
Discharge Voltage:	Air Discharge: $\pm 2\text{kV}$, $\pm 4\text{kV}$, $\pm 8\text{kV}$ (Direct) Contact Discharge: $\pm 2\text{kV}$, $\pm 4\text{kV}$ (Direct/Indirect)
Number of Discharge:	Air – Direct: 10 discharges per location (each polarity) Contact – Direct & Indirect: 25 discharges per location (each polarity) and min. 200 times in total
Discharge Mode:	Single Discharge
Discharge Period:	1-second minimum

9.2 Test Instruments

Description & Manufacturer	Model No.	Serial No.	Cal. Date	Cal. Due
KeyTek, ESD Simulator	MZ-15/EC	0504259	Oct. 25, 2016	Oct. 24, 2017

- Notes:
1. The calibration interval of the above test instruments is 12 months and the calibrations are traceable to NML/ROC and NIST/USA.
 2. The test was performed in ESD Room No. 1.
 3. Tested Date: Jul. 10, 2017

9.3 Test Arrangement

The discharges shall be applied in two ways:

- a. Contact discharges to the conductive surfaces and coupling planes:

The EUT shall be exposed to at least 200 discharges, 100 each at negative and positive polarity, at a minimum of four test points. One of the test points shall be subjected to at least 50 indirect discharges to the center of the front edge of the horizontal coupling plane. The remaining three test points shall each receive at least 50 direct contact discharges. If no direct contact test points are available, then at least 200 indirect discharges shall be applied in the indirect mode. Test shall be performed at a maximum repetition rate of one discharge per second.

- b. Air discharges at slots and apertures and insulating surfaces:

On those parts of the EUT where it is not possible to perform contact discharge testing, the equipment should be investigated to identify user accessible points where breakdown may occur. Such points are tested using the air discharge method. This investigation should be restricted to those area normally handled by the user. A minimum of 10 single air discharges shall be applied to the selected test point for each such area.

The basic test procedure was in accordance with EN/IEC 61000-4-2:

- a. Electrostatic discharges were applied only to those points and surfaces of the EUT that are accessible to users during normal operation.
- b. The test was performed with at least ten single discharges on the pre-selected points in the most sensitive polarity.
- c. The time interval between two successive single discharges was at least 1 second.
- d. The ESD generator was held perpendicularly to the surface to which the discharge was applied and the return cable was at least 0.2 meters from the EUT.
- e. Contact discharges were applied to the non-insulating coating, with the pointed tip of the generator penetrating the coating and contacting the conducting substrate.
- f. Air discharges were applied with the round discharge tip of the discharge electrode approaching the EUT as fast as possible (without causing mechanical damage) to touch the EUT. After each discharge, the ESD generator was removed from the EUT and re-triggered for a new single discharge. The test was repeated until all discharges were complete.
- g. At least ten single discharges (in the most sensitive polarity) were applied to the **Horizontal Coupling Plane** at points on each side of the EUT. The ESD generator was positioned at a distance of 0.1 meters from the EUT with the discharge electrode touching the **HCP**.
- h. At least ten single discharges (in the most sensitive polarity) were applied to the center of one vertical edge of the **Vertical Coupling Plane** in sufficiently different positions that the four faces of the EUT were completely illuminated. The **VCP** (dimensions 0.5m x 0.5m) was placed vertically to and 0.1 meters from the EUT.

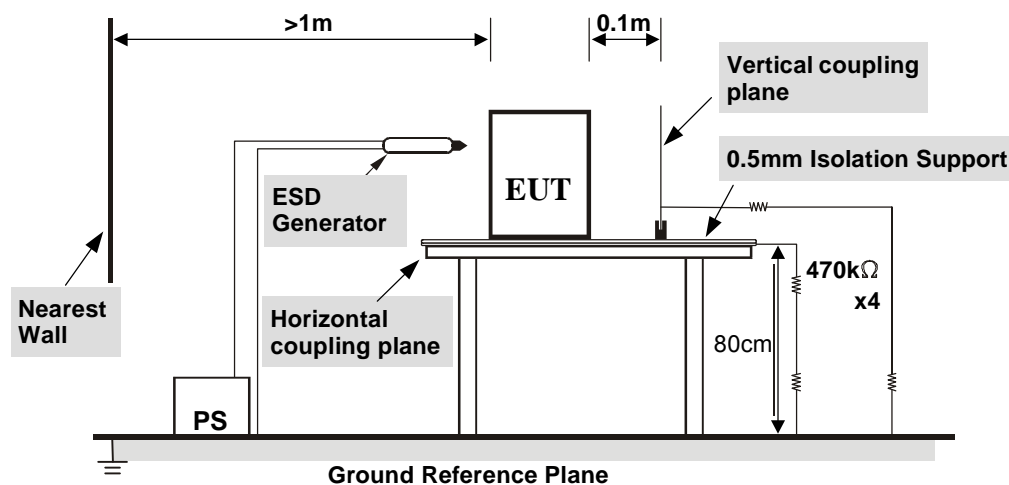

TABLE-TOP EQUIPMENT

The configuration consisted of a wooden table 0.8 meters high standing on the **Ground Reference Plane**. The **GRP** consisted of a sheet of aluminum at least 0.25mm thick, and 2.5 meters square connected to the protective grounding system. A **Horizontal Coupling Plane** (1.6m x 0.8m) was placed on the table and attached to the **GRP** by means of a cable with 940kΩ total impedance. The equipment under test, was installed in a representative system as described in section 7 of EN/IEC 61000-4-2, and its cables were placed on the **HCP** and isolated by an insulating support of 0.5mm thickness. A distance of 1-meter minimum was provided between the EUT and the walls of the laboratory and any other metallic structure.

For the actual test configuration, please refer to the related item – Photographs of the Test Configuration.

9.4 Test Results

Input Power	230Vac, 50Hz (system)	Tested by	Bernie Lu
Environmental Conditions	22 °C, 34% RH 1002 mbar	Test mode	Mode 1

Test Results of Direct Application

Discharge Level (kV)	Polarity (+/-)	Test Point	Contact Discharge	Air Discharge	Performance Criterion
2	+/-	1, 2	Note 1	N/A	A
4	+/-	1, 2	Note 2	N/A	B
2, 4, 8	+/-	3	N/A	Note 1	A

Description of test points of direct application: Please refer to following page for representative mark only.

Test Results of Indirect Application

Discharge Level (kV)	Polarity (+/-)	Test Point	Horizontal Coupling Plane	Vertical Coupling Plane	Performance Criterion
2, 4	+/-	Four Sides	Note 1	Note 1	A

Description of test points of indirect application:

1. Front side
2. Rear side
3. Right side
4. Left side

Note: 1. The EUT function was correct during the test.
 2. The LED off 1-3 seconds during the test, but self-recoverable after the test.

Description of Test Points

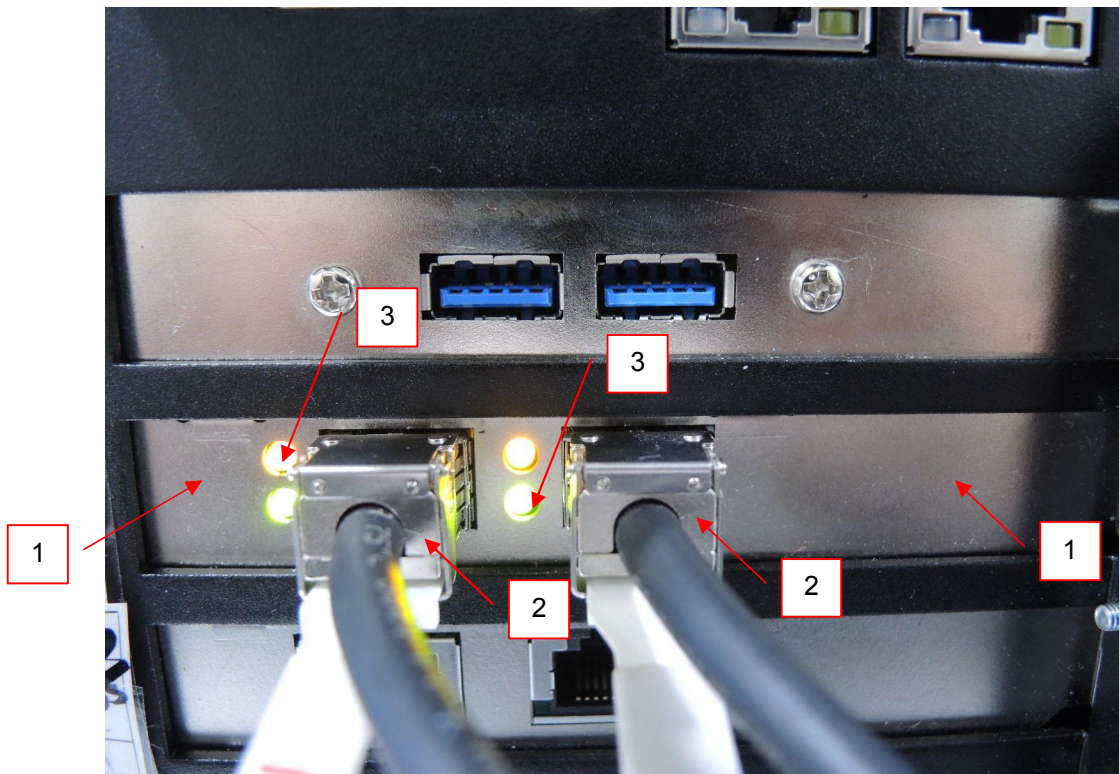

10 Radiated, Radio-frequency, Electromagnetic Field Immunity Test (RS)

10.1 Test Specification

Basic Standard:	EN/IEC 61000-4-3
Frequency Range:	80 MHz - 1000 MHz
Field Strength:	3 V/m
Modulation:	1kHz Sine Wave, 80%, AM Modulation
Frequency Step:	1 % of preceding frequency value
Polarity of Antenna:	Horizontal and Vertical
Antenna Height:	1.5m
Dwell Time:	3 seconds

10.2 Test Instruments

Description & Manufacturer	Model No.	Serial No.	Cal. Date	Cal. Due
Agilent Signal Generator	E8257D	MY48050465	Jun. 03, 2017	Jun. 02, 2018
PRANA RF Amplifier	AP32DP280	0811-894	NA	NA
TESEQ RF Amplifier	CBA1G-150	T44220	NA	NA
AR RF Amplifier	35S4G8AM4	0326094	NA	NA
AR RF Amplifier	100S1G4M3	0329249	NA	NA
AR Controller	SC1000M3	305910	NA	NA
Narda Broadband Field Meter	NBM-550	B-0872	Feb. 09, 2016	Feb. 08, 2018
BOONTON RF Voltage Meter	4232A	10180	May 19, 2017	May 18, 2018
BOONTON Power Sensor	51013-4E	34870	Jun. 02, 2017	Jun. 01, 2018
BOONTON Power Sensor	51013-4E	34873	Jun. 02, 2017	Jun. 01, 2018
AR Log-Periodic Antenna	AT6080	0329465	NA	NA
EMCO BiconiLog Antenna	3141	1001	NA	NA
AR High Gain Antenna	AT4002A	306533	NA	NA
AR High Gain Horn Antenna	AT4010	0329800	NA	NA
CHANCE MOST Full Anechoic Chamber (9x5x3m)	Chance Most	RS-002	Feb. 06, 2017	Feb. 05, 2018
Software	RS_V7.6	NA	NA	NA

- Notes:
1. The calibration interval of the above test instruments is 12/24 months and the calibrations are traceable to NML/ROC and NIST/USA.
 2. The test was performed in RS Room No.2.
 3. Tested Date: Jul. 8, 2017

10.3 Test Arrangement

The test procedure was in accordance with EN/IEC 61000-4-3.

- The testing was performed in a modified semi-anechoic chamber.
- The frequency range is swept from 80 MHz to 1000 MHz, with the signal 80% amplitude modulated with a 1kHz sine wave.
- The field strength level was 3 V/m.
- The test was performed with the EUT exposed to both vertically and horizontally polarized fields on each of the four sides.

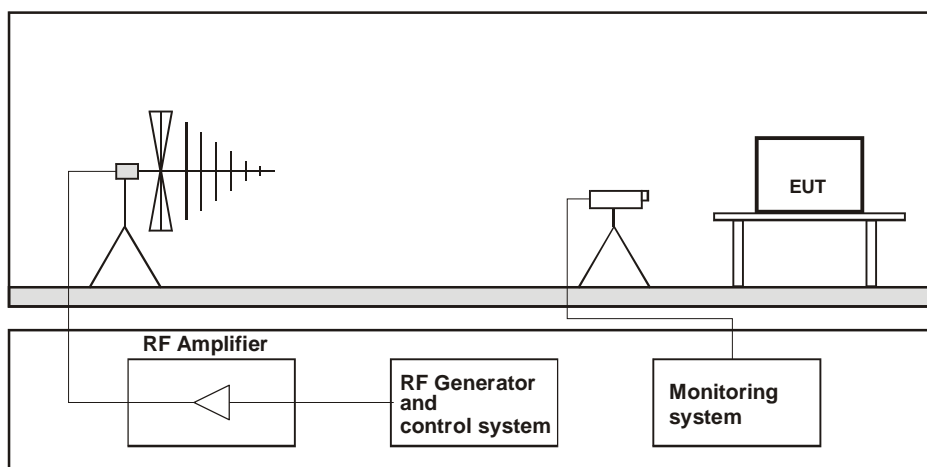

Table-top Equipment

The EUT installed in a representative system as described in section 7 of EN/IEC 61000-4-3 was placed on a non-conductive table 0.8 meters in height. The system under test was connected to the power and signal wire according to relevant installation instructions.

For the actual test configuration, please refer to the related item – Photographs of the Test Configuration.

10.4 Test Results

Input Power	230Vac, 50Hz (system)	Tested by	Bernie Lu
Environmental Conditions	22 °C, 60% RH	Test mode	Mode 1

Frequency (MHz)	Polarity	Azimuth(°)	Applied Field Strength		Observation	Performance Criterion
			(V/m)	Modulation		
80 -1000	V&H	0	3	80% AM (1kHz)	Note	A
80 -1000	V&H	90	3	80% AM (1kHz)	Note	A
80 -1000	V&H	180	3	80% AM (1kHz)	Note	A
80 -1000	V&H	270	3	80% AM (1kHz)	Note	A

Note: The EUT function was correct during the test.

11 Electrical Fast Transient/Burst Immunity Test (EFT)

11.1 Test Specification

Basic Standard:	EN/IEC 61000-4-4
Test Voltage:	Signal / telecommunication port: ± 0.5 kV Input DC power port: N/A Input AC power port: N/A
Impulse Repetition Frequency:	xDSL telecommunication port: 100kHz others: 5kHz
Impulse Wave Shape:	5/50 ns
Burst Duration:	0.75 ms for 100kHz Repetition Frequency 15 ms for 5kHz Repetition Frequency
Burst Period:	300 ms
Test Duration:	1 min.

11.2 Test Instruments

Description & Manufacturer	Model No.	Serial No.	Cal. Date	Cal. Due
Haefely, EFT Generator	PEFT 4010	154954	Apr. 17, 2017	Apr. 16, 2018
Haefely, Capacitive Clamp	IP4A	155173	Apr. 17, 2017	Apr. 16, 2018

- Notes:
1. The calibration interval of the above test instruments is 12 months and the calibrations are traceable to NML/ROC and NIST/USA.
 2. The test was performed in EFT Room.
 3. Tested Date: Jul. 8, 2017

11.3 Test Arrangement

- Both positive and negative polarity discharges were applied.
- The distance between any coupling devices and the EUT should be 0.5 m for table-top equipment testing, and 1.0 m for floor standing equipment.
- The duration time of each test sequential was 1 minute.
- The transient/burst waveform was in accordance with EN/IEC 61000-4-4, 5/50 ns.

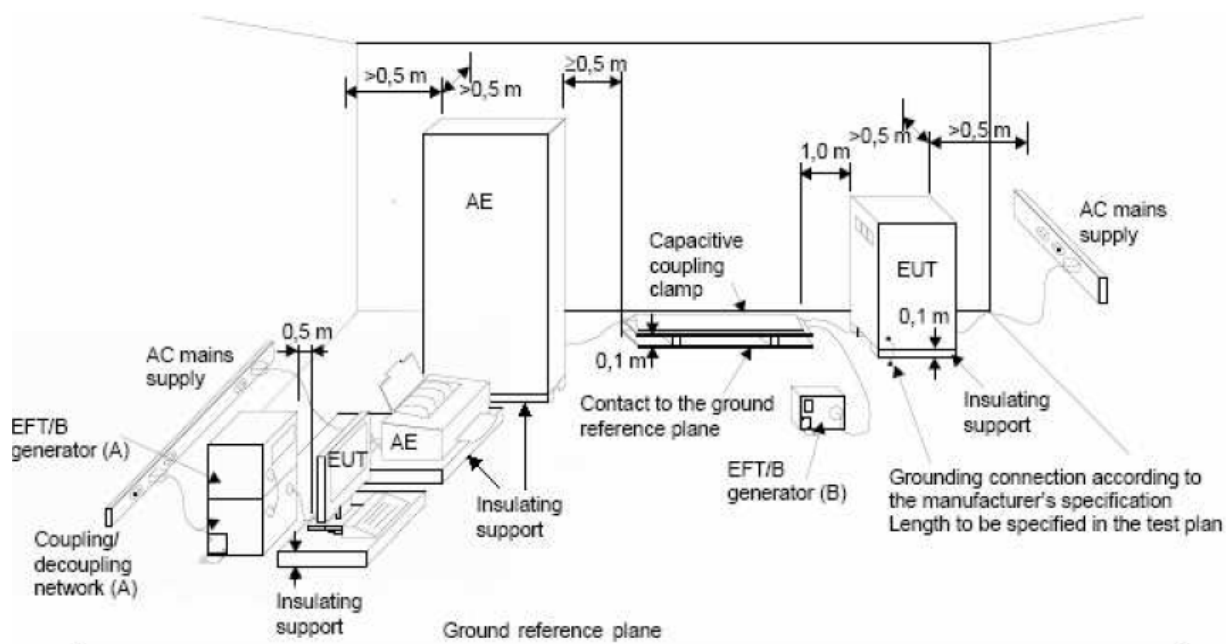

NOTE:

- location for supply line coupling
- location for signal lines coupling

For the actual test configuration, please refer to the related item – Photographs of the Test Configuration.

11.4 Test Results

Input Power	230Vac, 50Hz (system)	Tested by	Bernie Lu
Environmental Conditions	22 °C, 67% RH	Test mode	Mode 1

Signal / telecommunication port

Voltage (kV)	Test Point	Polarity (+/-)	Observation	Performance Criterion
0.5	SFP x 2	+/-	Note	A

Note: The EUT function was correct during the test.

12 Immunity to Conducted Disturbances Induced by RF Fields (CS)

12.1 Test Specification

Basic Standard:	EN/IEC 61000-4-6
Frequency Range:	0.15 MHz - 80 MHz
Voltage Level:	3 V
Modulation:	1kHz Sine Wave, 80%, AM Modulation
Frequency Step:	1 % of preceding frequency value
Dwell Time	3 seconds

12.2 Test Instruments

Description & Manufacturer	Model No.	Serial No.	Cal. Date	Cal. Due
ROHDE & SCHWARZ Signal Generator	SML03	101801	Jan. 06, 2017	Jan. 05, 2018
Digital Sweep Function Generator	8120	984801	NA	NA
AR Power Amplifier	75A250AM1	306331	NA	NA
FCC Coupling Decoupling Network	FCC-801-M2-16A	01047	Jun. 21, 2017	Jun. 20, 2018
FISCHER CUSTOM COMMUNICATIONS EM Injection Clamp	F-203I-23mm	455	NA	NA
FISCHER CUSTOM COMMUNICATIONS Current Injection Clamp	F-120-9A	361	NA	NA
B&K Ear Simulator	4185	2553594	NA	NA
EM TEST Coupling Decoupling Network	CDN M1/32A	306508	Jun. 21, 2017	Jun. 20, 2018
TESEQ Coupling Decoupling Network	CDN T800	34428	Jun. 21, 2017	Jun. 20, 2018
FCC Coupling Decoupling Network	FCC-801-T4	02031	Jun. 21, 2017	Jun. 20, 2018
EM TEST Coupling Decoupling Network	CDN T2	306509	Jun. 21, 2017	Jun. 20, 2018
R&S Power Sensor	NRV-Z5	837878/039	Oct. 27, 2016	Oct. 26, 2017
R&S Power Meter	NRVD	837794/040	Oct. 27, 2016	Oct. 26, 2017
TESEQ Coupling Decoupling Network	CDN M232	37702	Jun. 21, 2017	Jun. 20, 2018
TESEQ Coupling Decoupling Network	CDN M332	41258	Jun. 21, 2017	Jun. 20, 2018
TESEQ Coupling Decoupling Network	CDN M332	41256	Jun. 21, 2017	Jun. 20, 2018
TESEQ Coupling Decoupling Network	CDN T400A	28569	Jun. 21, 2017	Jun. 20, 2018
TESEQ Coupling Decoupling Network	CDN T8-10	40376	Jun. 21, 2017	Jun. 20, 2018
Software	CS_V7.4.2	NA	NA	NA

- Notes:
1. The calibration interval of the above test instruments is 12 months and the calibrations are traceable to NML/ROC and NIST/USA.
 2. The test was performed in CS Room No. 1.
 3. Tested Date: Jul. 8, 2017

12.3 Test Arrangement

- The EUT shall be tested within its intended operating and climatic conditions.
- An artificial hand was placed on the hand-held accessory and connected to the ground reference plane.
- One of the CDNs not used for injection was terminated with 50 ohm, providing only one return path. All other CDNs were coupled as decoupling networks.
- The frequency range is swept from 150 kHz to 80 MHz, using the signal level established during the setting process and with a disturbance signal of 80 % amplitude. The signal is modulated with a 1 kHz sine wave, pausing to adjust the RF signal level or the switch coupling devices as necessary. Where the frequency is swept incrementally, the step size shall not exceed 1 % of the preceding frequency value.
- Attempts should be made to fully exercise the EUT during testing, and to fully interrogate all exercise modes selected for susceptibility.

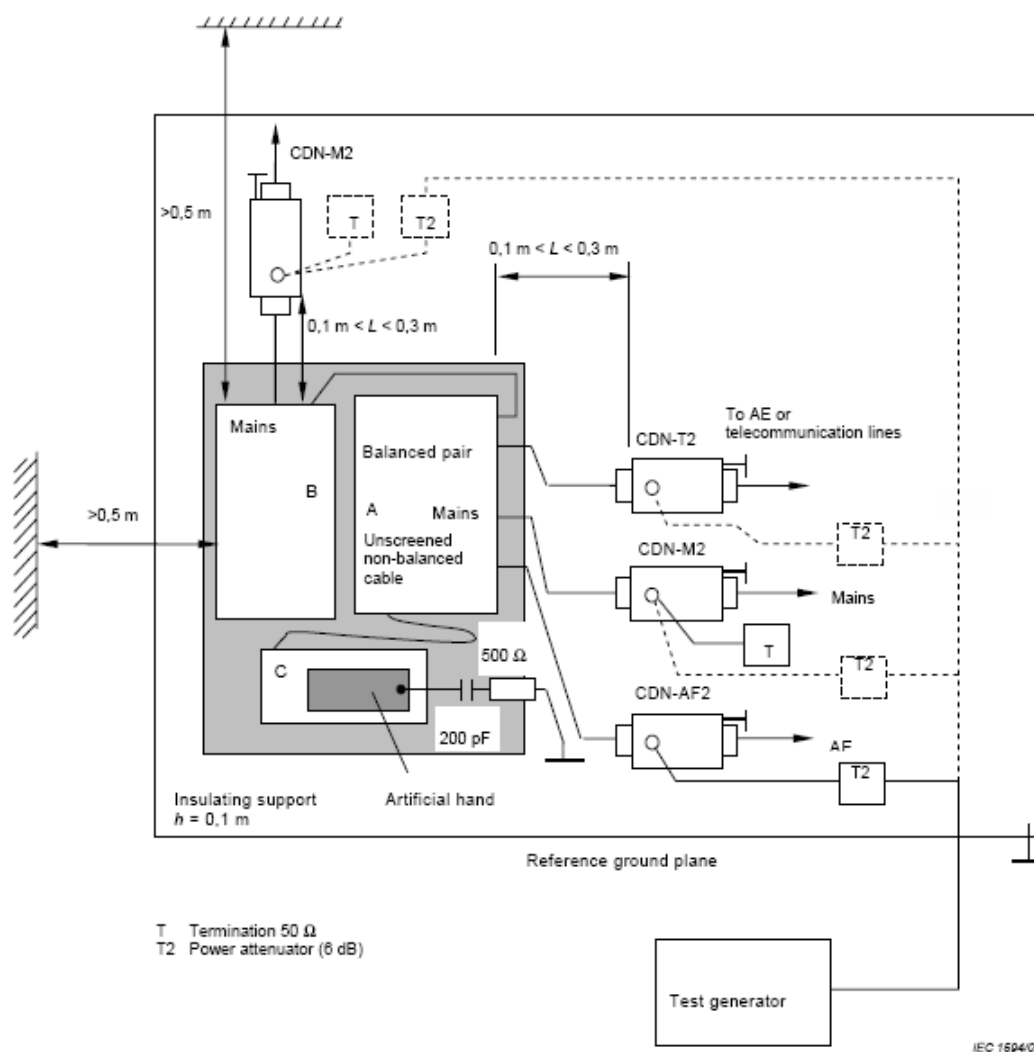

- Note:**
- The EUT clearance from any metallic obstacles shall be at least 0,5 m.
 - Interconnecting cables (≤ 1 m) belonging to the EUT shall remain on the insulating support.
 - The equipment to be tested is placed on an insulating support of 0.1 meters height above a ground reference plane. All relevant cables shall be provided with the appropriate coupling and decoupling devices at a distance between 0.1 meters and 0.3 meters from the projected geometry of the EUT on the ground reference plane.

For the actual test configuration, please refer to the related item – Photographs of the Test Configuration.

12.4 Test Results

Input Power	230Vac, 50Hz (system)	Tested by	Bernie Lu
Environmental Conditions	22 °C, 62% RH	Test mode	Mode 1

Frequency (MHz)	Level (Vrms)	Tested Line	Injection Method	Return Path	Observation	Performance Criterion
0.15 – 80	3	SFP	EM-Clamp	CDN-M3	Note	A

Note: The EUT function was correct during the test.

13 Power Frequency Magnetic Field Immunity Test

13.1 Test Specification

Basic Standard:	EN/IEC 61000-4-8
Frequency Range:	50Hz
Field Strength:	1 A/m
Observation Time:	1 minute
Inductance Coil:	Rectangular type, 1 m x 1 m

13.2 Test Instruments

Description & Manufacturer	Model No.	Serial No.	Cal. Date	Cal. Due
HAEFELY Magnetic Field Tester	MAG 100	083794-06	NA	NA
COMBINOVA Magnetic Field Meter	MFM10	224	Apr. 17, 2017	Apr. 16, 2018

- Notes:
1. The calibration interval of the above test instruments is 12 months and the calibrations are traceable to NML/ROC and NIST/USA.
 2. The test was performed in EMS Room No. 1
 3. Tested Date: Jul. 7, 2017

13.3 Test Arrangement

- a. The equipment is configured and connected to satisfy its functional requirements.
- b. The power supply, input and output circuits shall be connected to the sources of power supply, control and signal.
- c. The cables supplied or recommended by the equipment manufacturer shall be used. 1 meter of all cables used shall be exposed to the magnetic field.

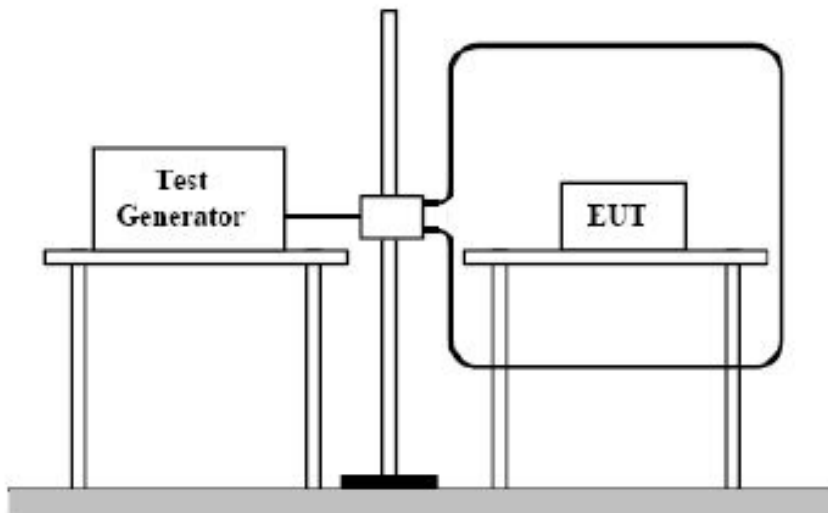

TABLETOP EQUIPMENT

The equipment shall be subjected to the test magnetic field by using the induction coil of standard dimension (1 m x 1 m). The induction coil shall then be rotated by 90 degrees in order to expose the EUT to the test field with different orientations.

For the actual test configuration, please refer to the related item – Photographs of the Test Configuration.

13.4 Test Results

Input Power	230Vac, 50Hz (system)	Tested by	Bernie Lu
Environmental Conditions	22 °C, 64% RH	Test mode	Mode 1

Application	Frequency (Hz)	Field Strength (A/m)	Observation	Performance Criterion
X - Axis	50	1	Note	A
Y - Axis	50	1	Note	A
Z - Axis	50	1	Note	A

Note: The EUT function was correct during the test.

14 Pictures of Test Arrangements

14.1 Conducted Emission from the AC Mains Power Port



14.2 Radiated Emission at Frequencies up to 1GHz

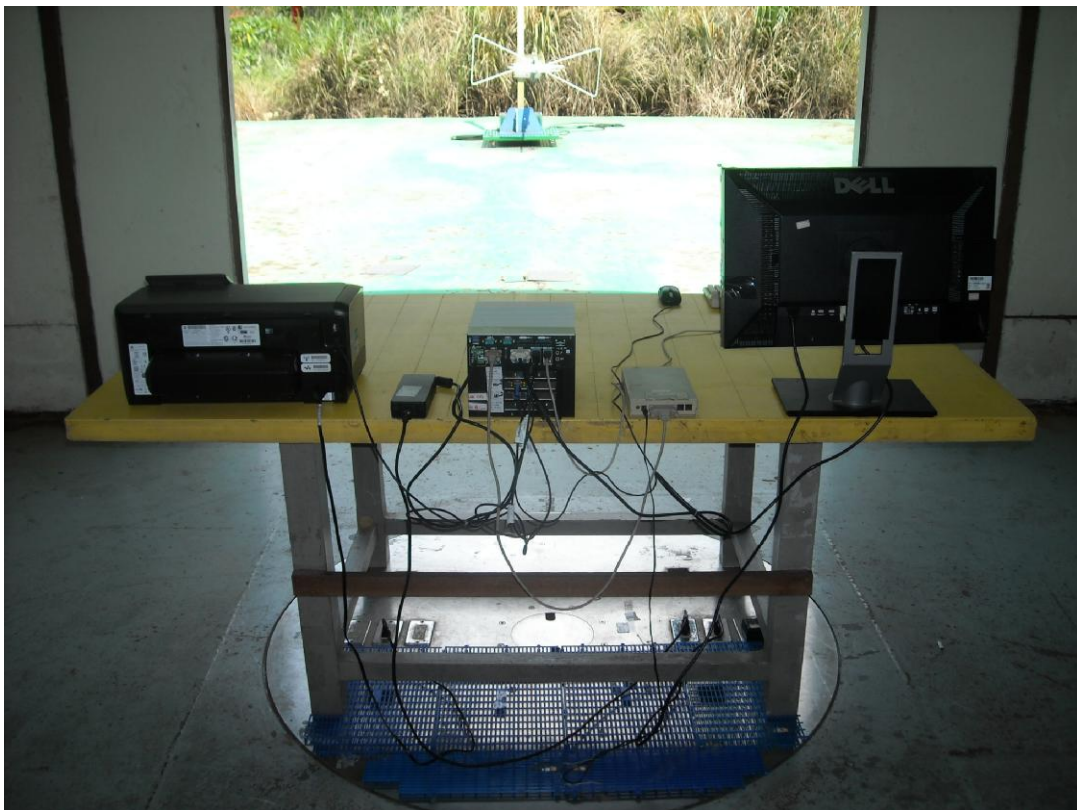

14.3 Radiated Emission at Frequencies above 1GHz



14.4 Electrostatic Discharge Immunity Test (ESD)



14.5 Radio-frequency, Electromagnetic Field Immunity Test (RS)

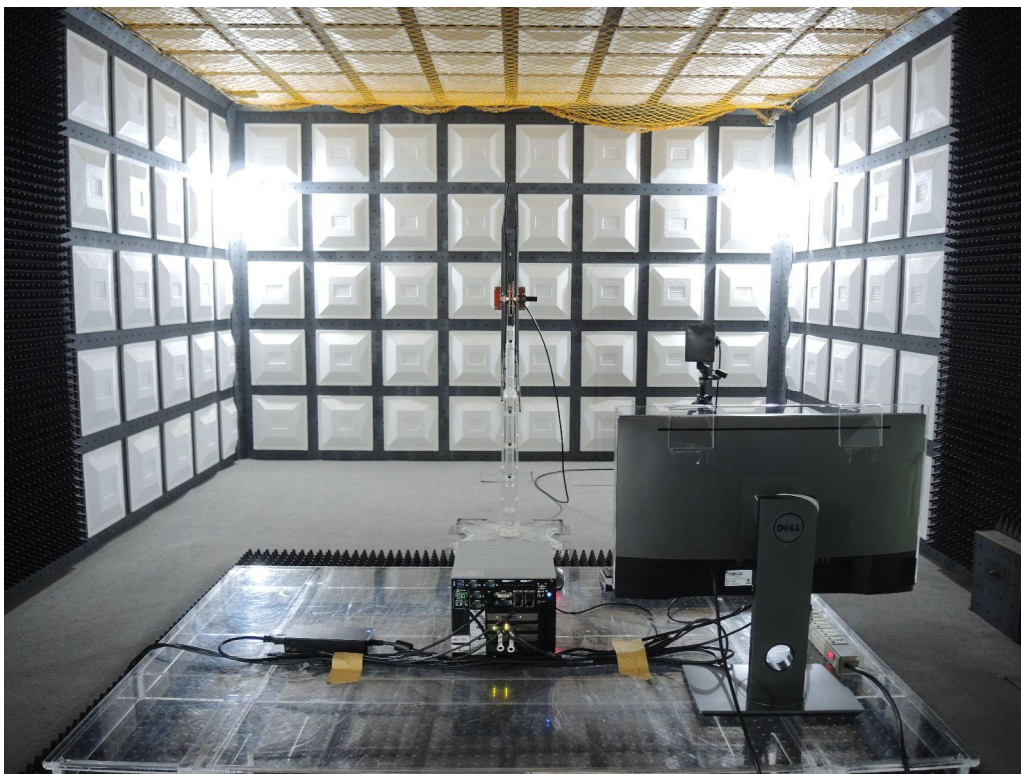
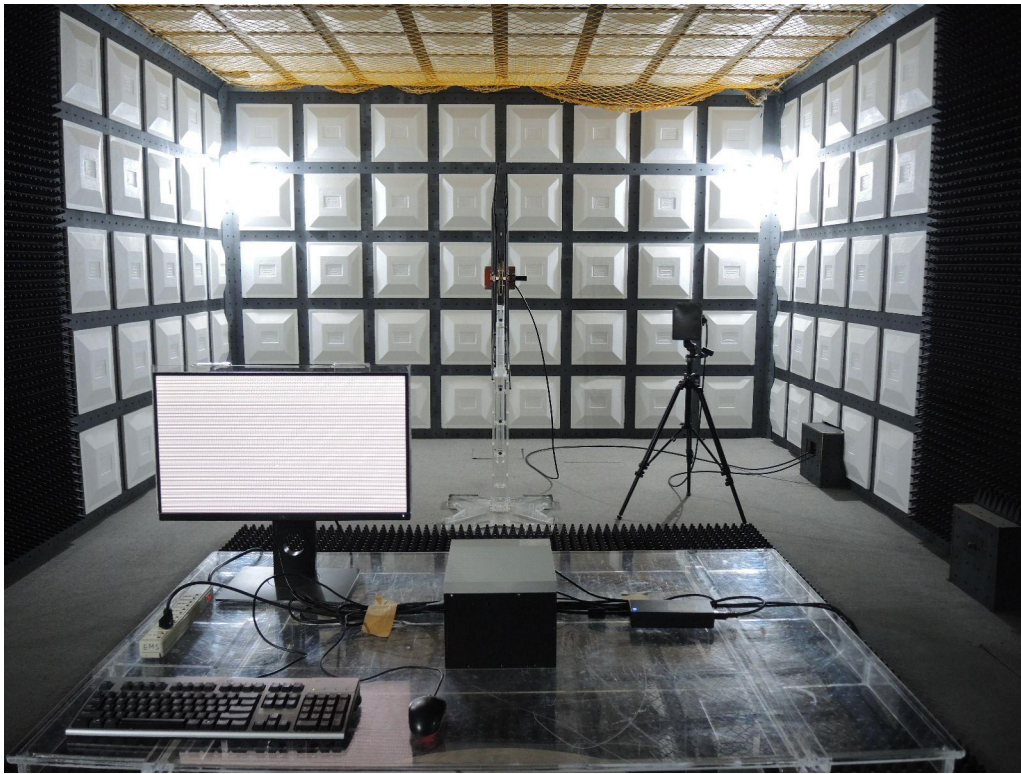

14.6 Electrical Fast Transient/Burst Immunity Test (EFT)

Signal ports

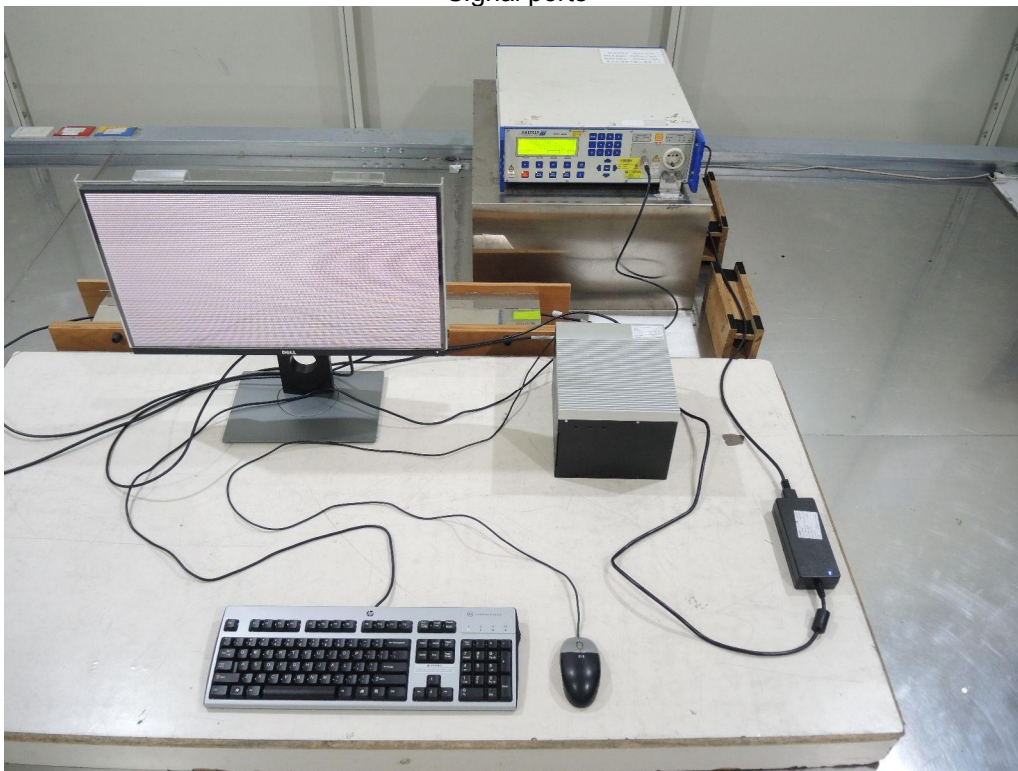

14.7 Conducted Disturbances Induced by RF Fields (CS)

Signal ports

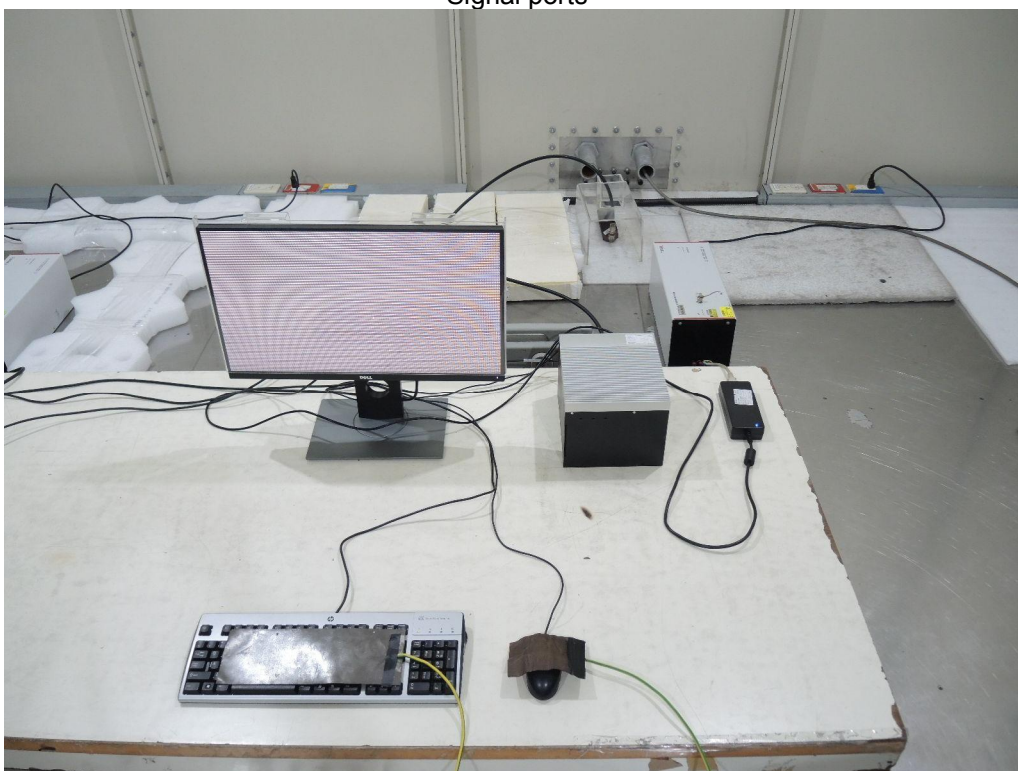

14.8 Power Frequency Magnetic Field Immunity Test (PFMF)



Appendix – Information on the Testing Laboratories

We, Bureau Veritas Consumer Products Services (H.K.) Ltd., Taoyuan Branch, were founded in 1988 to provide our best service in EMC, Radio, Telecom and Safety consultation. Our laboratories are accredited and approved according to ISO/IEC 17025.

If you have any comments, please feel free to contact us at the following:

Linko EMC/RF Lab

Tel: 886-2-26052180

Fax: 886-2-26051924

Hsin Chu EMC/RF/Telecom Lab

Tel: 886-3-6668565

Fax: 886-3-6668323

Hwa Ya EMC/RF/Safety Lab

Tel: 886-3-3183232

Fax: 886-3-3270892

Email: service.adt@tw.bureauVeritas.com

Web Site: www.bureauVeritas-adt.com

The address and road map of all our labs can be found in our web site also.

--- END ---